

# HYDROPONICS AND GREEN HOUSE CONTROLLER

MODEL HGC-003

OWNER'S MANUAL

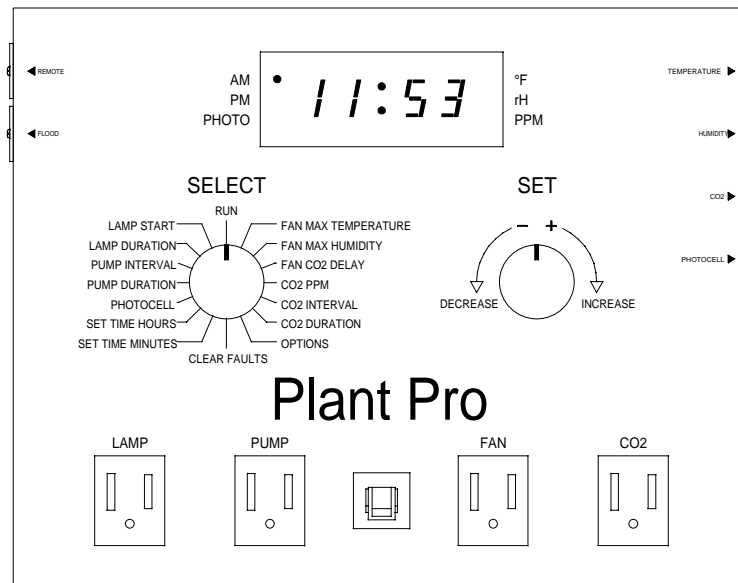

SOLATEL INC.

[www.solatel.com](http://www.solatel.com)



# TABLE OF CONTENTS

INTRODUCTION.....	2
HOW TO USE THIS MANUAL.....	2
FEATURES.....	2
LOCATION OF CONTROLS.....	4
QUICK START.....	5
INTRODUCTION.....	5
QUICK START ITEMS.....	6
CONNECTING THE CABLES.....	6
SETTING THE CLOCK.....	6
SETTING THE LAMP TIME.....	7
SETTING THE PUMP TIME.....	7
SETTING THE VENT FAN TEMPERATURE.....	7
OTHER SETTINGS.....	7
FINAL CONNECTION AND RUN.....	8
INSTALLATION.....	10
INTRODUCTION.....	10
POWER.....	10
PLANT PRO.....	10
SENSOR CABLE.....	10
FLOOD SENSOR.....	11
TEMPERATURE SENSOR.....	12
HUMIDITY SENSOR.....	13
CO2 SENSOR.....	14
PHOTOCELL SENSOR.....	15
LAMP, PUMP, FAN AND CO2 OUTLETS.....	16
OPERATION.....	17
INTRODUCTION.....	17
SELECT KNOB AND SET KNOB.....	17
GENERAL OPERATION ISSUES.....	18
CLOCK.....	18
RUN.....	20
LAMP.....	22
PUMP.....	23
FAN AND CO2.....	24
OPTIONS.....	29
PHOTOCELL MODES.....	33
FAULTS.....	40
APPENDIX.....	43
PROBLEM SOLVING.....	43
SPECIFICATIONS.....	44
INDEX.....	45

# INTRODUCTION

This manual describes the setup and use of your new Hydroponics and Greenhouse Control System. This system is easy to use for simple growing areas but has advanced features for more complex needs. Setup is very simple with an uncluttered control panel. This manual starts with simple descriptions and goes on to more detail in later chapters.

## ***HOW TO USE THIS MANUAL***

The **Location of Controls** chapter (page 4) shows the Plant Pro's front panel and what each part is called. See the **Quick Start** chapter (page 5) for a brief installation of a basic system. Later chapters give all the details including more complex systems. The **Installation** chapter (page 10) explains how to hook up each part of a complex system in more detail. The **Operation** chapter (page 17) gives details on setup and running. The **Appendix** (page 43) has various useful information including a **Problem Solving** section (page 43) if you are having problems. And last, but not least, is an **Index** (page 45) to look things up if you can't find them in the **Table of Contents** (page 1) in the front of this manual.

## ***FEATURES***

### FOUR OUTLETS FOR EASY PLUG-IN

- Lamp
- Pump
- Vent Fan
- CO2 Tank or Generator

### FOUR SENSORS WITH 10 FOOT CABLES

- Temperature
- Humidity
- CO2 PPM
- Photocell (light level)

### EASY SET-UP

- One knob to select what you want
- ... a second knob to set it
- ..... and a display to show it

### BASIC AND ADVANCED CONTROL MODES

- Simple control by time clock or any of three photocell modes
- CO2 tank or generator can be controlled by time clock or CO2 Sensor

### ADVANCED SECURITY CAPABILITIES

- Sensor shuts off all outlets in case of flooding
- Remotely triggered shut off
- Remote alarm triggering

### NEW FEATURES

- Adjustable Fan Delay also available for Monitored CO2
- Optional display blanking at night
- RUN Mode Rotate Display always shows temperature, humidity and CO2
- Additional pump modes
- Additional vent fan modes

- Adjustable sensor switching offset

# LOCATION OF CONTROLS

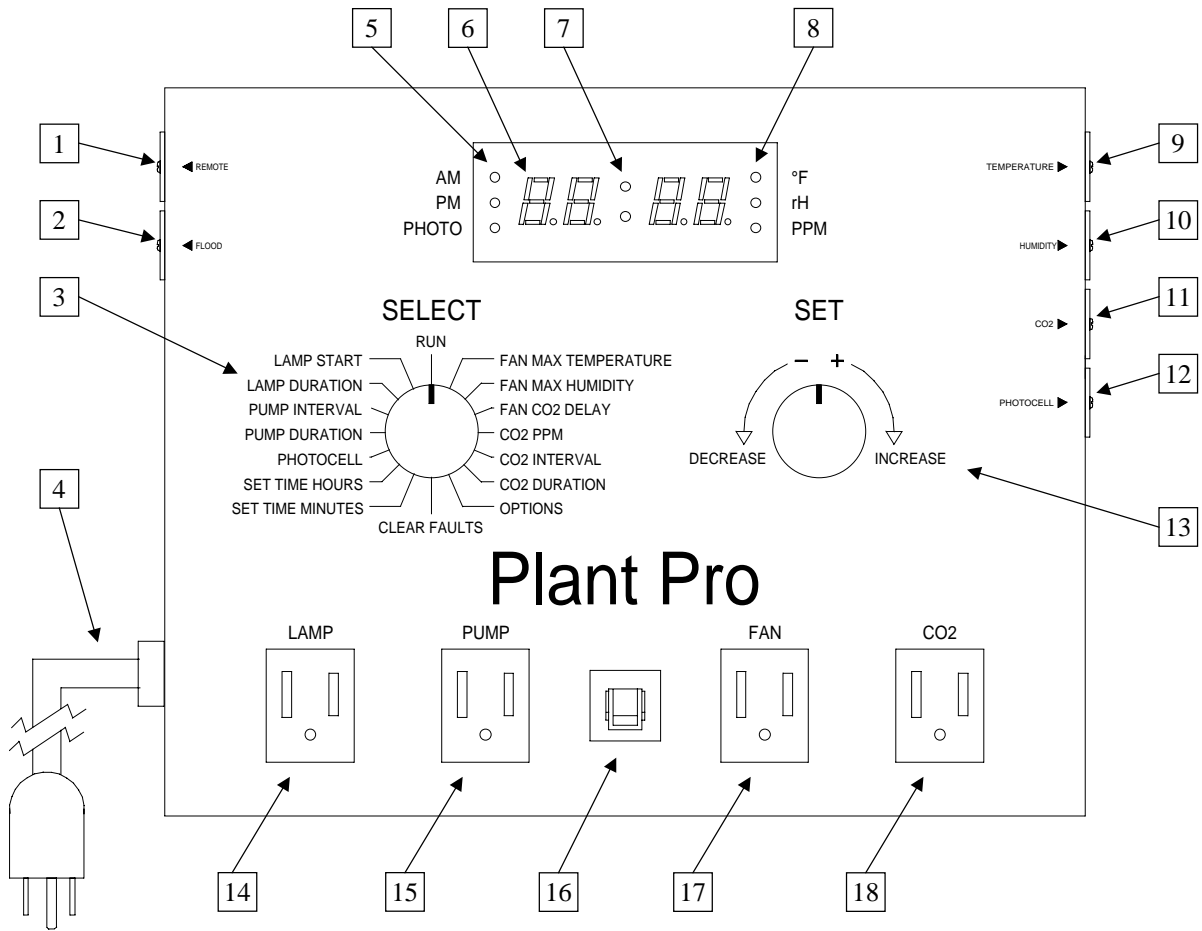

**Figure 1 Plant Pro Front View**

- |                                   |                                  |
|-----------------------------------|----------------------------------|
| 1. Remote connector               | 10. Humidity Sensor connector    |
| 2. Flood Sensor connector         | 11. CO2 Sensor connector         |
| 3. Select Knob                    | 12. Photocell Sensor connector   |
| 4. Power cord                     | 13. Set Knob                     |
| 5. AM, PM, and Photo indicators   | 14. Lamp Outlet                  |
| 6. Digital display                | 15. Pump Outlet                  |
| 7. Colon indicators               | 16. Circuit Breaker              |
| 8. °F, rH, and CO2 PPM indicators | 17. Vent Fan Outlet              |
| 9. Temperature Sensor connector   | 18. CO2 Tank or Generator Outlet |

## QUICK START

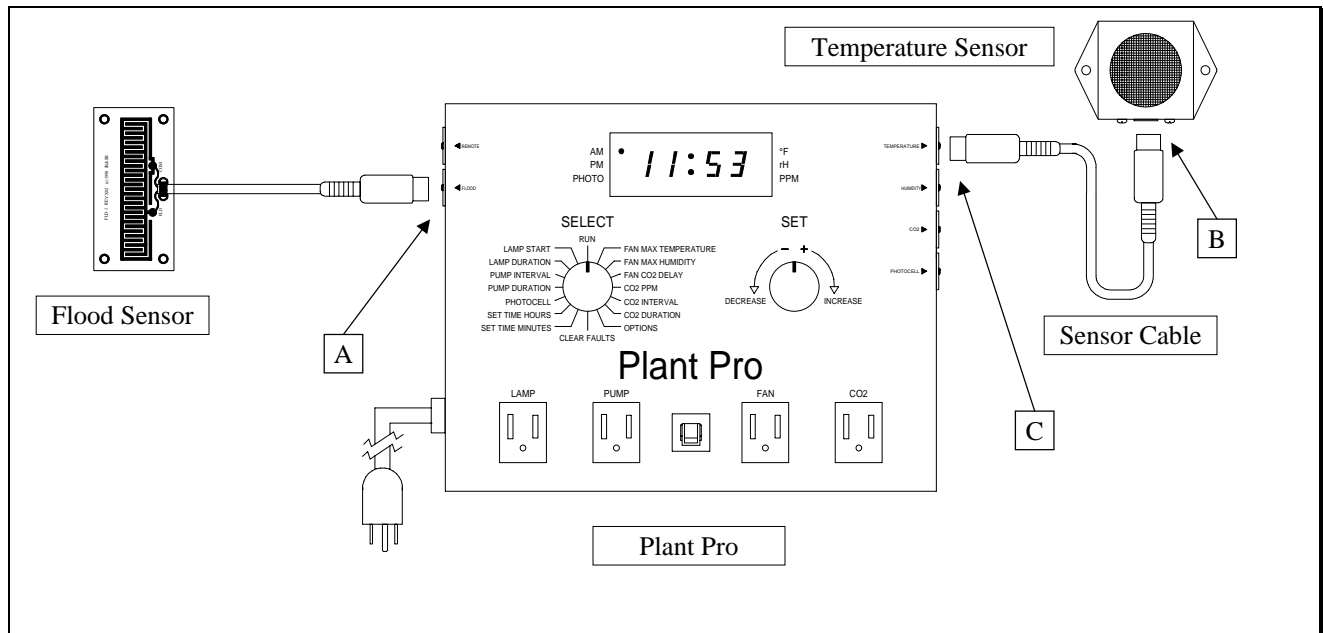

Figure 2 QUICK START Sensor Connection

## INTRODUCTION

The Quick Start instructions are for a basic Plant Pro system using a Temperature Sensor and a Flood Sensor. Even though you may have purchased other sensors, such as the Humidity Sensor, Solatel CO2 sensor, or Photocell Sensor, it is best to set up the basic system first. This will let you get the general idea of how the Select control Knob and the Set control Knob work together with the display to allow for quick and easy setup of all the Plant Pro's functions. Once you are familiar with this unique set up method, you will be able to set up even the most complex system in a matter of seconds.

In general, you select one of the Plant Pro's functions with the Select Knob. You view the present value on the display. Then you choose the value you want that function to have with the Set Knob. You enter these values into the Plant Pro's computer when the Select Knob is placed in the RUN position. It's as simple as that.

This setup will let you control your lighting system, irrigation pumps, and vent fan. You will set the time that the lamp turns on each day and how many hours it stays on. If the lamp is off, the pump is off too. You will set how often the pump comes on, that is, every hour, every two hours, and so on while the lamp is on. You will set how many minutes the pump stays on. You will set the temperature for the vent fan. If it gets hotter than your setting, then the vent fan turns on. If it gets cooler than your setting, then the vent fan turns off.

## QUICK START ITEMS

These instructions are for a system with the items below. See later sections for more complex systems. It is recommended that you first get your system running in this configuration and then go on to a more complex system.

ITEM	DESCRIPTION
1	Plant Pro
2	Flood Sensor
3	Temperature Sensor
4	Sensor Cable
5	Lamp
6	Pump
7	Vent Fan

## CONNECTING THE CABLES

Connect the sensors as shown in **Fig. 2** using the following instructions.

1. Be sure the Plant Pro is not plugged into the wall yet.
2. Place the Plant Pro in a dry, convenient place near the growing area.
3. Mount the Flood Sensor where it will get wet if there is an overflow problem but will not be stepped on.
4. Plug the cable from the Flood Sensor into the Plant Pro's Flood Sensor connector [A].
5. Mount the Temperature Sensor where it can measure the typical temperature.
6. Plug one end of the Sensor Cable into the Temperature Sensor [B].
7. Plug the other end of the Sensor Cable into the Plant Pro's Temperature Sensor connector [C].
8. Don't plug cords into the Plant Pro's outlets yet.
9. Turn the Select Knob on the Plant Pro to point to RUN.

## SETTING THE CLOCK

1. Plug the Plant Pro's power cord into a wall outlet.
2. All of the Plant Pro's display will light up for one second, then the display will start flashing once a second. If nothing lights up after several seconds, with the Select Knob still pointing to RUN, turn the Set Knob 6 or more "clicks" in the DECREASE direction. The display should then start flashing. If not, see **Problem Solving** (page 43) for more information.
3. Set the time using the following steps. For each step, turn the Select Knob to the indicated position. Then turn the Set Knob as described. Do each step in sequence.

STEP	SELECT KNOB	SET KNOB
1	SET HOURS	Turn to show the correct hours. If the correct hours show but not the correct AM or PM, keep turning until all are correct. Although the minutes are displayed, the Set Knob will not change them.
2	SET MINUTES	Turn to show the correct minutes. Although the hours are displayed, the Set Knob will not change them.
3	RUN	Now the new time will be used. The display should stop flashing (if the display continues to flash, see <b>Faults</b> (page 40) ). Turn 6 or more "clicks" in the DECREASE direction. The display will show the time for two seconds. Next the display will show various sensor readings in sequence, each for two seconds. When a sensor is displayed, its related indicator will be lit. The sequence of displays will then repeat. Turning the Set Knob will set what is displayed here (including blanking the display). See <b>Run</b> (page 20) for details.

See **Clock** (page 18) for more details.

## SETTING THE LAMP TIME

This sets up the lamp in Time Clock Mode. First get your system running in Time Clock Mode. See **Lamp** (page 22) for more details. If you have a Photocell Sensor, later set it up to control the lamp. The **Photocell Sensor** (page 15) and **Photocell Modes** (page 29) sections describe how to do this.

STEP	SELECT KNOB	SET KNOB
1	LAMP START	Turn to show the time to turn on the lamp. If the correct hours are displayed but not the correct AM or PM, keep turning until all are correct. Do not set to "PCon" or "PCLn".
2	LAMP DURATION	Turn to show the number of hours for the lamp to remain on. If the lamp is to be always on, set to 24:00. Do not set to "PCon".
3	PHOTOCELL	Turn in the INCREASE direction until "nonE" shows. This tells the Plant Pro to ignore the Photocell Sensor, whether connected or not.
4	RUN	Now the new settings will be used. If the display starts to flash, see <b>Faults</b> (page 40).

## SETTING THE PUMP TIME

See **Pump** (page 23) for more details.

STEP	SELECT KNOB	SET KNOB
1	PUMP INTERVAL	Turn to show the number of hours between pump cycles. Set to 1:00 to turn on at the beginning of every hour the lamp is on, 2:00 for every other hour, and so on.
2	PUMP DURATION	Turn to show the number of minutes the pump is on each pump cycle.
3	RUN	Now the new settings will be used.

## SETTING THE VENT FAN TEMPERATURE

See **Fan and CO2** (page 24) for more details.

STEP	SELECT KNOB	SET KNOB
1	FAN MAX TEMPERATURE	Turn to show the desired maximum growing area temperature. The vent fan will turn on when the actual temperature is above this, off when below. Do not set to "nonE"
2	RUN	Now the new settings will be used.

## OTHER SETTINGS

These settings turn off the other functions that are not used for the initial setup in this Quick Start section. First get this initial setup running. Later on add them if you have purchased Humidity or CO2 Sensors or have CO2 dispensing equipment. The **Installation** (page 10) and **Operation** (page 17) chapters describe how to add them.

STEP	SELECT KNOB	SET KNOB
1	FAN MAX HUMIDITY	Turn in the INCREASE direction until "nonE" shows. This tells the Plant Pro to ignore the Humidity Sensor, whether connected or not.
2	FAN CO2 DELAY	Turn in the DECREASE direction until :00 shows.
3	CO2 PPM	Turn in the INCREASE direction until "nonE" shows. This tells the Plant Pro to ignore the CO2 Sensor, whether connected or not.
4	CO2 INTERVAL	Turn in the DECREASE direction until :05 shows.
5	CO2 DURATION	Turn in the DECREASE direction until :00 shows.
6	OPTIONS	Turn in the DECREASE direction until 0000 shows.

### FINAL CONNECTION AND RUN

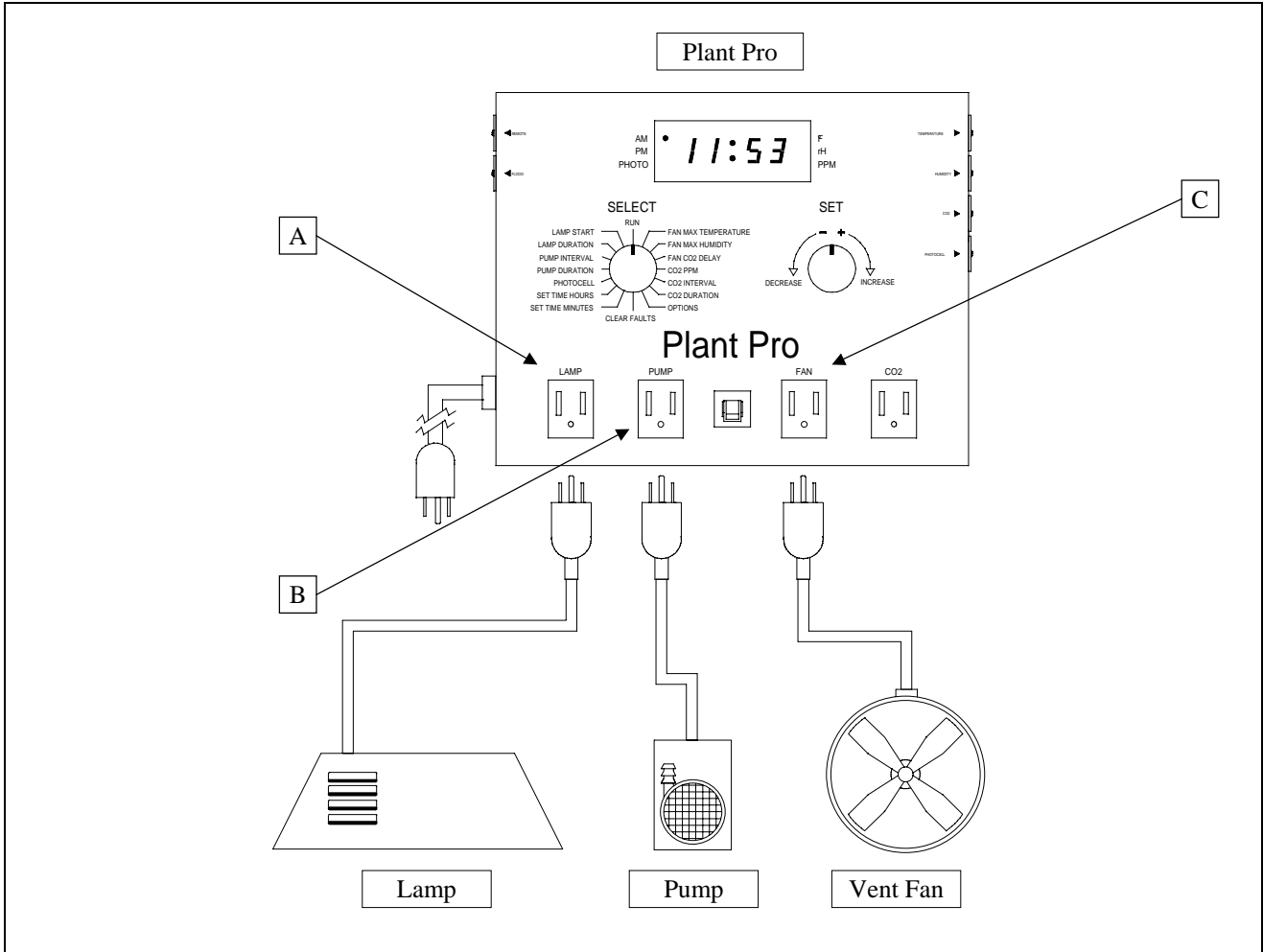

**Figure 3 QUICK START Lamp, Pump, and Vent Fan Connection**

1. If the lamp, pump or vent fan have switches on them, turn them off.
2. Plug the lamp into the Plant Pro outlet labeled LAMP [A].
3. Plug the pump into the Plant Pro outlet labeled PUMP [B].
4. Plug the vent fan into the Plant Pro outlet labeled FAN [C].
5. If the lamp, pump or vent fan have switches on them, turn them on
6. The system should now run according to the settings previously entered.

Your QUICK START system is now ready to use.

**Note: Be sure to check that FAN CO2 DELAY is set to zero (:00) and OPTIONS is set to zeros (00 00) until you fully understand these functions, otherwise the Plant Pro may not perform as expected.**

**Leave these functions set to zero if you are not using them.**

# INSTALLATION

## INTRODUCTION

This chapter explains in detail how to hook up each part of the system. See the **Operation** chapter (page 17) for how to run it. First are subjects that affect all systems. Next, sensor installation is given. Because you may only have some of the sensors, installation for each sensor is shown separately. See the sections that cover your system. Finally, the installation of devices into the outlets is shown. Drawings, especially cable lengths, are not necessarily to scale.

## POWER

The Plant Pro has a power cord that will plug into a standard wall outlet. North American models operate on 120 volts AC at 60 Hz. It is also sometimes described as 110 volts. There are four outlets on the Plant Pro. Each outlet can provide up to 12 Amps. The Plant Pro has a 15 Amp circuit breaker for all outlets plus its internal circuitry combined. Approximately 1/2 Amp should be allowed for the Plant Pro's internal circuitry. It is recommended that the total of all outlets combined be 14.5 Amps or less. This is enough to power a 1000 watt lamp, a pump, a vent fan, and a CO2 tank or generator. If the Plant Pro's circuit breaker trips, especially when outlets are switching on, then the total current should be reduced. The Plant Pro can control equipment requiring more current using a Solatel PWX-1 or PWX-D20 Power Expander.

## PLANT PRO

The Plant Pro should be placed in a dry location near the growing area. Avoid places where it will get wet or stepped on. Put it close enough to an outlet for its power cord to reach. If not, use a heavy duty extension cord rated for 15 Amps or more. The Plant Pro should be located to allow the display to be seen while turning the knobs. Space on the front is needed to plug in the power cords of the devices being controlled. Space on the sides is needed for the Sensor Cables to be plugged in. See **Location of Controls** (page 4) for details on the Plant Pro.

## SENSOR CABLE

The Sensor Cable is 10 feet long. Some sensors, such as the Flood Sensor, have one end of their cable already attached to the sensor. The other end is plugged into the appropriate connector on the side of the Plant Pro. Others, such as the Temperature Sensor, have a connector on the sensor too. For them, a separate cable with connectors on both ends is used. Either end of the Sensor Cable can be plugged into the Plant Pro or sensor. The connectors have 5 pins arranged in a half circle. If they do not plug in easily, don't force them, just turn the connector until the pins are aligned to get them to plug in. Plug them in all the way and they will hold securely. Do not use cables other than the ones supplied by Solatel. The cable should be placed in a dry area and avoid being stepped on, crushed, or cut. Although Sensor Cables can be bundled together, avoid bundling them with power cords to minimize electrical interference.

Sensor Cables should be plugged and unplugged only when power is off to the Plant Pro. If due to circumstances a Sensor Cable *must* be removed while power is on, unplug the end at the Plant Pro. This will eliminate voltages on the pins of the cable at the sensor end. The voltages are not high enough to cause a shock. However, if the pins at the sensor end are shorted by an object, such as screw head, they can cause malfunction if the other end is still plugged into a powered Plant Pro. Of course, for sensors such as the Flood Sensor or Solatel CO2 Sensor, there is no connector at the sensor end and such shorting is not a problem.

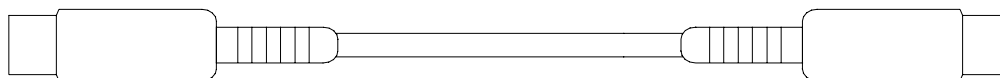
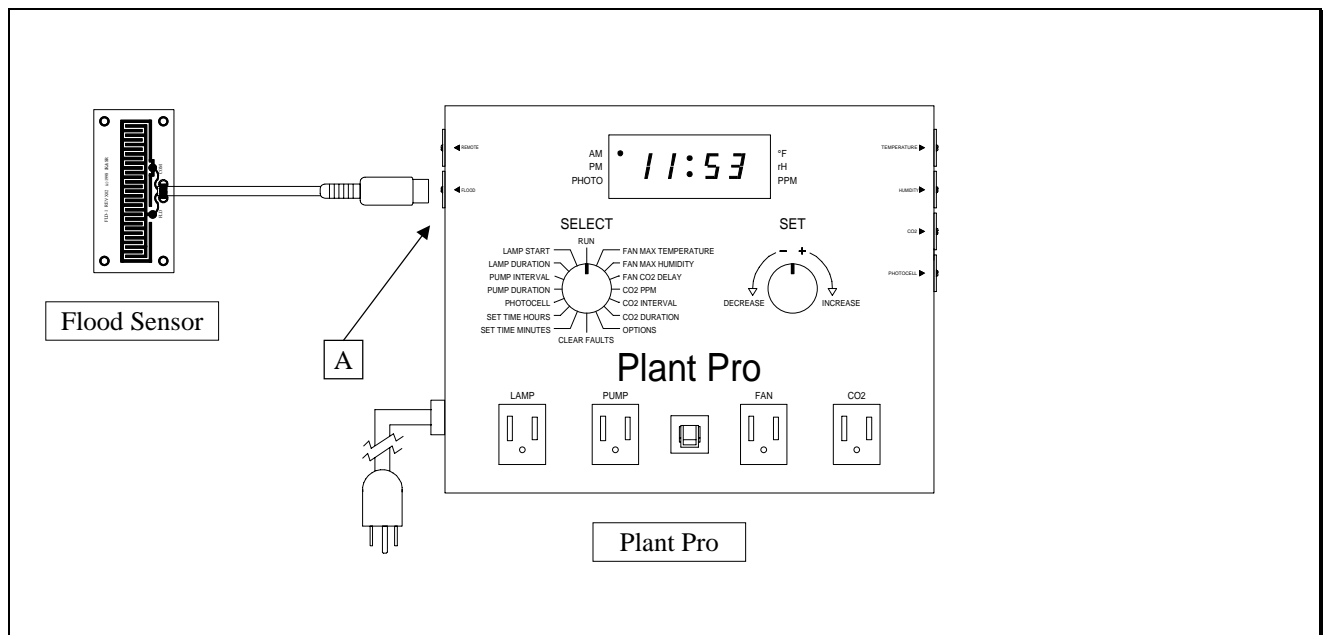

**Figure 4 Sensor Cable**

(length not to scale)

## FLOOD SENSOR

The Flood Sensor is used to detect a spill or overflow of water or nutrient solution. It is not used to control normal pumping such as in a flood and drain system. Many hobby hydroponics units are located in locations where considerable water damage could result if drain lines became clogged with roots or plugged by fallen leaves. Solatel has included as a standard accessory with each system a Flood Sensor to be located on the floor near the nutrient reservoir. Should overflow flooding occur, this sensor will immediately shut off the pump as well as the rest of the system until reset by the owner, thus greatly minimizing damage. All outlets are turned off to reduce the risk of electrical shock. The display also begins flashing to alert you of the problem. The Plant Pro waits for the flood to be continuously present for 1 to 2 seconds before responding to prevent false alarms. See **Faults** (page 40) for details and what to do if this happens.



**Figure 5 Flood Sensor Installation**

1. Mount the Flood Sensor where it will get wet if there is an overflow problem. Put it where it will not be stepped on. Place it with the shiny metal side up. It can be screwed down using the mounting holes or taped down. Don't block liquid from reaching the shiny metal pattern because this is what detects the flooding.
2. Plug the cable from the Flood Sensor into the Plant Pro's Flood Sensor connector [A].

## TEMPERATURE SENSOR

The Temperature Sensor measures the temperature of your growing area. Because it has a 10 foot cable it can be placed where needed, away from the Plant Pro. It should be placed where it can measure the typical temperature. It has two mounting flanges which allow it to be mounted with screws or tape. It measures the temperature of air flowing through its grill which should not be blocked. Avoid placing it where it will be splashed.

The Temperature Sensor reads from 32 to 110 degrees Fahrenheit (°F) in steps of 1 degree. Its temperature reading is used to control vent fan operation and CO2 dispensing. See **Fan and CO2** (page 24) for details on this. The temperature reading can be displayed on the Plant Pro. See **RUN** (page 20) for details on how to display it.

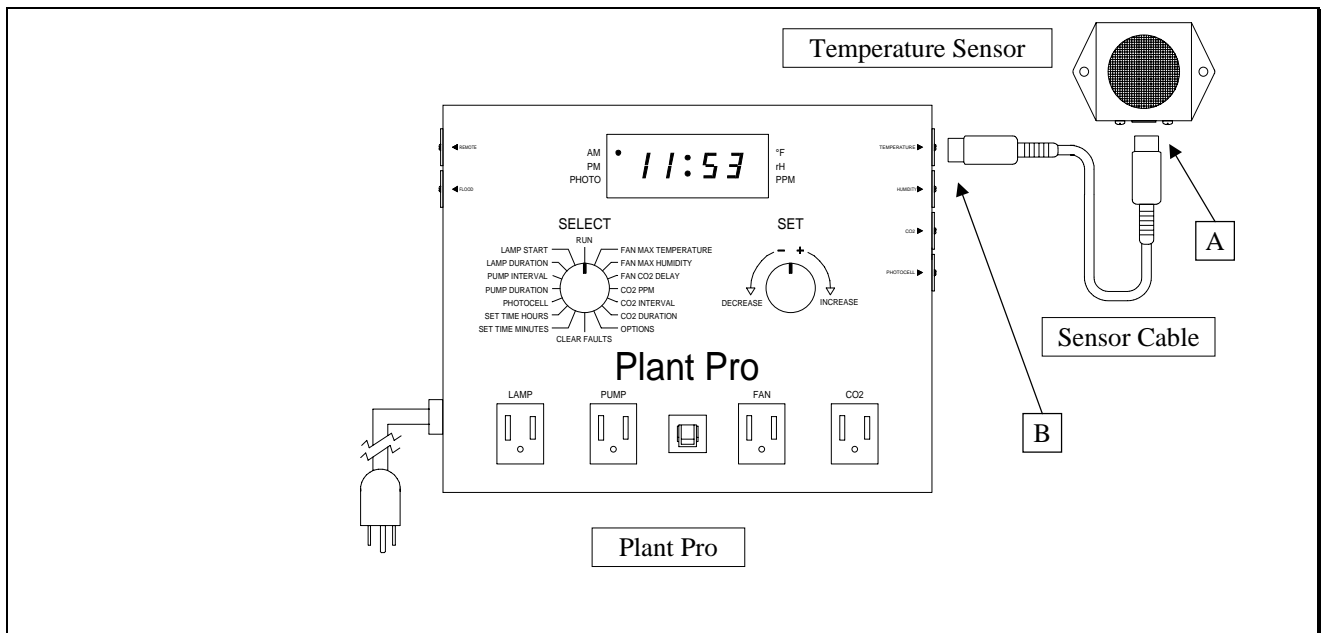

**Figure 6 Temperature Sensor Installation**

1. Mount the Temperature Sensor where it can measure the typical temperature. Do not block the grill.
2. Plug one end of the Sensor Cable into the Temperature Sensor [A].
3. Plug the other end of the Sensor Cable into the Plant Pro's Temperature Sensor connector [B].

## HUMIDITY SENSOR

The Humidity Sensor measures the humidity of your growing area. Because it has a 10 foot cable it can be placed where needed, away from the Plant Pro. It should be placed where it can measure the typical humidity. It has two mounting flanges which allow it to be mounted with screws or tape. It measures the humidity of air flowing through its grill so this should not be blocked. Avoid placing it where it will be splashed.

The Humidity Sensor reads 0 to 100% relative humidity (rH) in steps of 1%. Its humidity reading is used to control vent fan operation and CO2 dispensing. See **Fan and CO2** (page 24) for details on this. The humidity reading can be displayed on the Plant Pro. See **Run** (page 20) for details on how to display it.

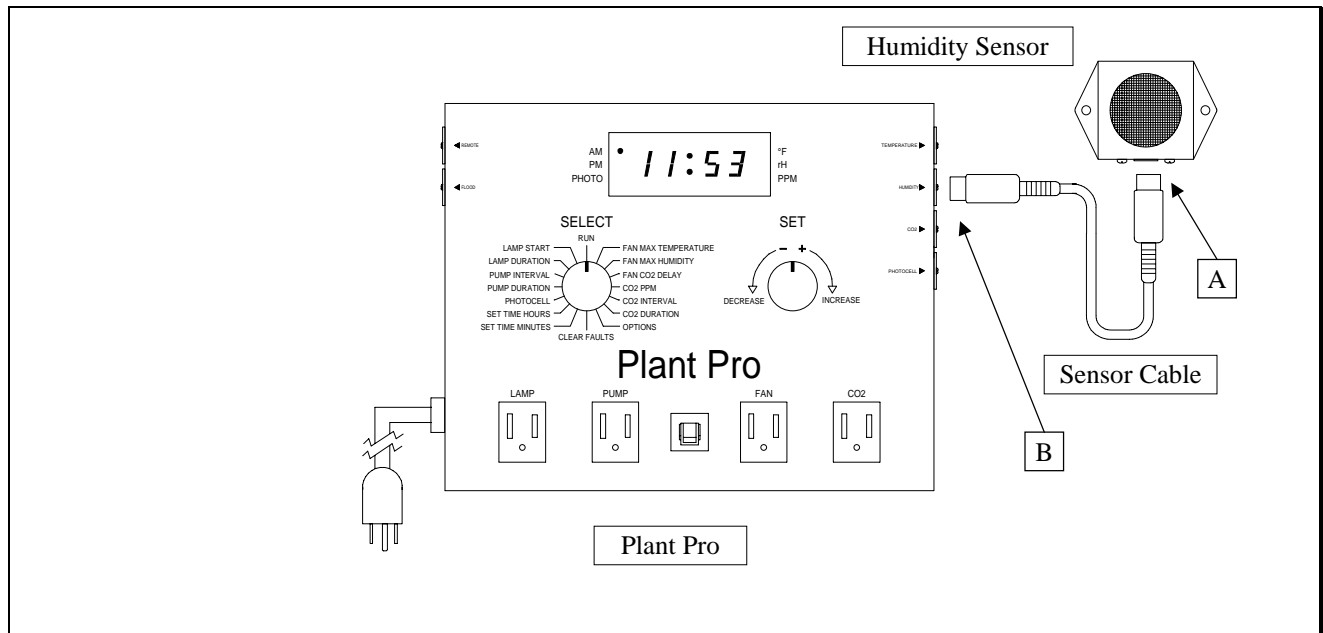

**Figure 7 Humidity Sensor Installation**

1. Mount the Humidity Sensor where it can measure the typical humidity. Do not block the grill.
2. Plug one end of the Sensor Cable into the Humidity Sensor [A].
3. Plug the other end of the Sensor Cable into the Plant Pro's Humidity Sensor connector [B].

## CO2 SENSOR

The CO2 Sensor measures the CO2 concentration in your growing area. Because it has a 10 foot cable it can be placed where needed, away from the Plant Pro. It should be placed where it can measure the typical CO2 level. It measures the CO2 level of air flowing through its slits in the front so these should not be blocked. Avoid placing it where it will be splashed. It has a separate power pack which is plugged into a standard wall outlet to provide it power.

The CO2 Sensor reads 0 to 2000 parts per million (PPM) concentration of carbon dioxide in steps of 10 PPM. Its CO2 reading is used to control CO2 dispensing. See **Fan and CO2** (page 24) for details on this. The reading can be displayed on the Plant Pro. See **RUN** (page 20) for details on how to display it.

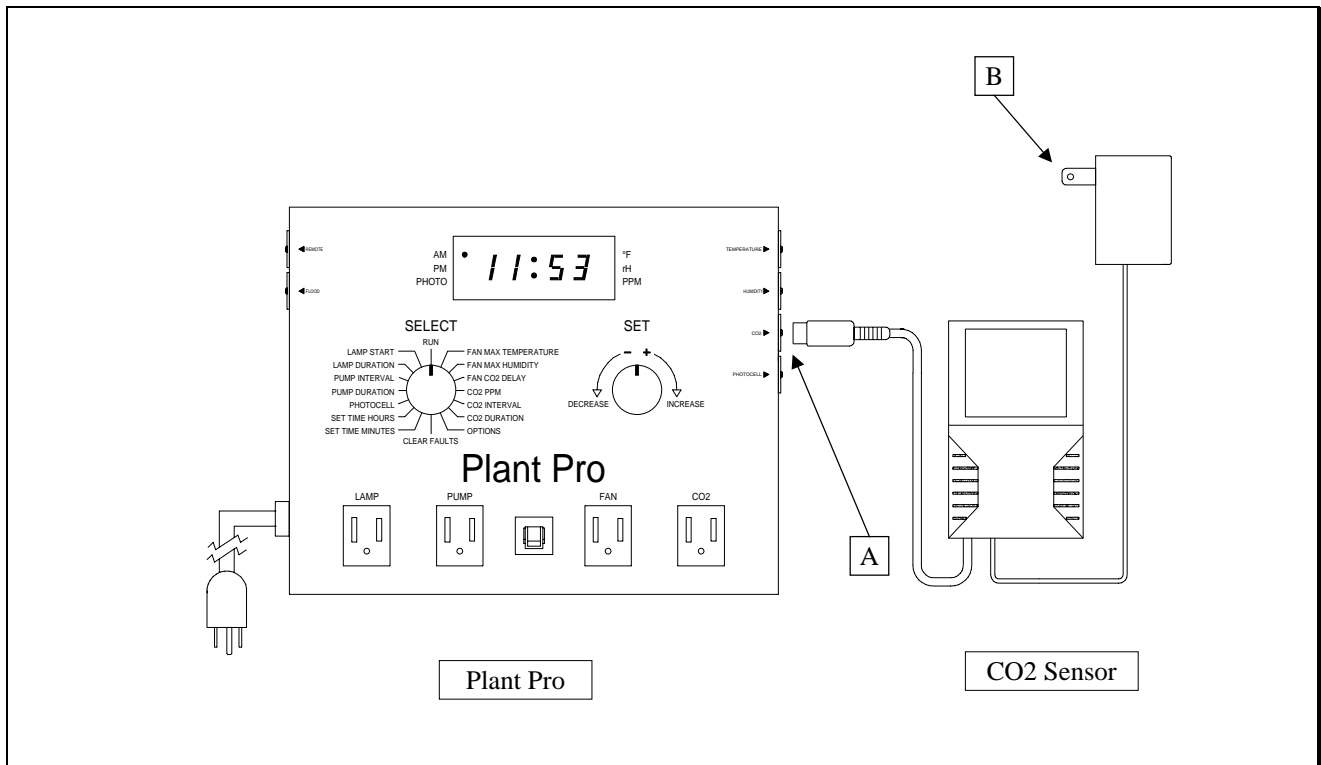

**Figure 8 CO2 Sensor Installation**

1. Mount the CO2 Sensor where it can measure the typical CO2 concentration. Do not block the air slits. The CO2 Sensor can be placed on a table or shelf or mounted on the wall. For wall mounting, put a nail, screw, or hook in the wall and attach the CO2 Sensor using the hanger in the back of the sensor.
2. Plug the cable from the CO2 Sensor into the Plant Pro's CO2 Sensor connector [A].
3. Plug the CO2 Sensor's power pack into a wall outlet [B]

## PHOTOCELL SENSOR

The Photocell Sensor measures the level of natural light from the sun. Because it has a 10 foot cable it can be placed where needed, away from the Plant Pro. The Photocell Sensor should be placed where it can measure natural light, not artificial light. It has two mounting flanges which allow it to be mounted with screws or tape. The flanges are located on the front of the Photocell Sensor, next to the clear area where light goes in. This is the opposite of the Temperature and Humidity Sensors where the flanges are on the back. This allows the Photocell Sensor to be mounted on the inside of a window facing outwards towards the sun. Light from the lamp should be avoided because it will give a false reading. Be careful that the Photocell Sensor is oriented away from night time light sources such as street lights, porch lights, auto headlights, window lights, and such. The Photocell Sensor measures the light coming in through the clear area so this should not be blocked. Avoid placing it where it will be splashed.

The Photocell Sensor reads 0 to 100 in an arbitrary scale in steps of 1 (this is not the same as foot-candles or lux). It detects relative darkness and brightness, usually for the detection of night and day. Its light level reading is used to control the lamp and therefore also the pump, vent fan and CO2. This is only done in Photocell Modes and has no effect in Time Clock Mode. See **Photocell Modes** (page 29) for details on this. The reading can be displayed on the Plant Pro. See **Run** (page 20) for details on how to display it.

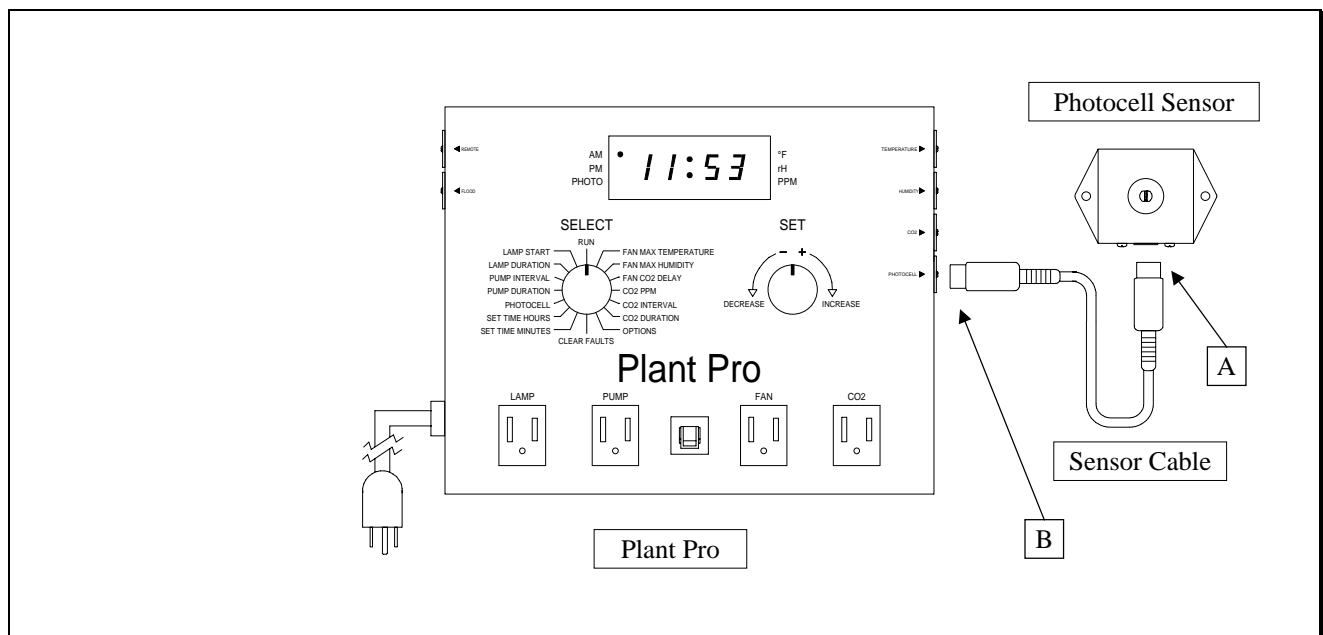
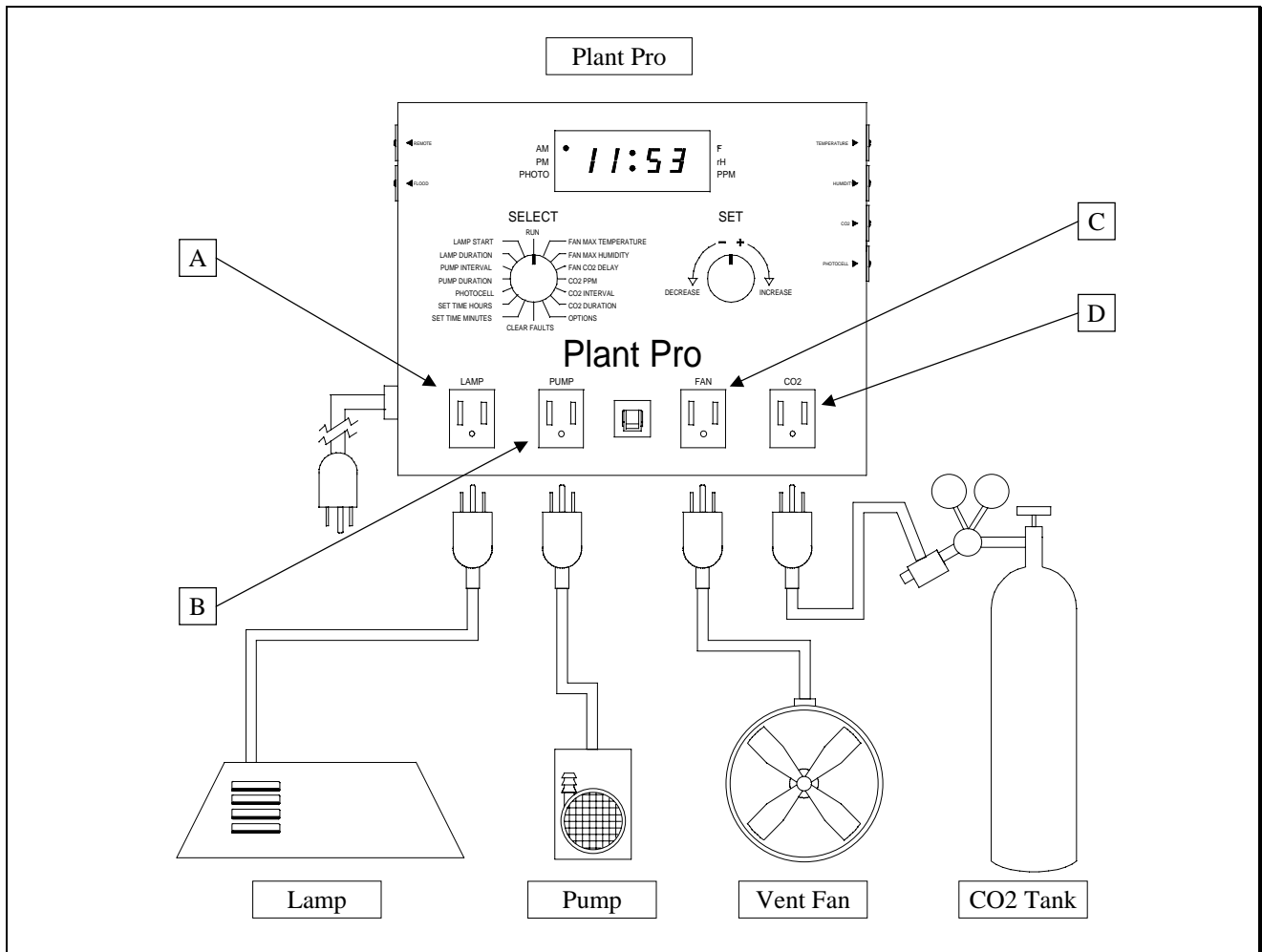

Figure 9 Photocell Sensor Installation

1. Mount the Photocell Sensor where it can measure light from the sun but not the lamp or other light sources.
2. Plug one end of the Sensor Cable into the Photocell Sensor [A].
3. Plug the other end of the Sensor Cable into the Plant Pro's Photocell Sensor connector [B].

## LAMP, PUMP, FAN AND CO2 OUTLETS

There are 4 outlets on the front of the Plant Pro labeled Lamp, Pump, Fan, and CO2. The Lamp Outlet can control a 1000 Watt Metal Halide or High Pressure Sodium lamp or an equivalent number of smaller lamps. The Pump Outlet is for the irrigation pump. The Fan Outlet is for a vent fan to provide ventilation or cooling if the temperature or humidity get above your settings. The Fan Outlet is not for a circulation fan. The CO2 outlet is for controlling the solenoid valve of a CO2 tank or the transformer of a CO2 generator. It is not for the CO2 Sensor. Ordinary extension cords or power strips can be used to provide more outlets or longer cord lengths. They should be rated for at least the current used. Each outlet can provide up to 12 Amps and it is recommended that the total of all outlets combined be 14.5 Amps or less. See **Power** (page 10) for more information.



**Figure 10 Lamp, Pump, Vent Fan, and CO2 Tank Installation**

1. Plug power cord from lamp into Lamp Outlet [A]
2. Plug power cord from pump into Pump Outlet [B]
3. Plug power cord from vent fan into Fan Outlet [C]
4. Plug power cord from CO2 tank or generator (not shown) into CO2 Outlet [D]

# OPERATION

## **INTRODUCTION**

This chapter describes the operation of the Plant Pro and its sensors. See the **Installation** chapter (page 10) for how to hook them up. In this Operation chapter there are first some sections on general issues. Then there is a section on each major function. For example, pump operation is a function and has its own section. For each function there is an overview, descriptions of different operating modes (if any), detailed descriptions of each of the function's settings, and a chart showing step-by-step setup of all settings for the function. This chapter, in general, assumes the default Options setting. For further information on advanced operating modes, See **Options** (page 29).

## **SELECT KNOB AND SET KNOB**

### VIEWING AND CHANGING A SETTING

There are two knobs, the Select Knob and the Set Knob. Both knobs make a small "click" when they are turned. They can be turned in either direction. They work together to select and then set each of the settings. A setting is information you give to the Plant Pro to tell it what to do. For example, pump operation involves two settings, PUMP INTERVAL and PUMP DURATION. The names of all of the settings are listed around the Select Knob. You select a setting by turning the Select Knob until the knob's pointer is lined up with the desired setting. The display will show the value of the setting that has been selected. Only one setting can be displayed at a time. Each setting has a range of values that it can be. For example, the PUMP DURATION setting can be any value from 0 to 60 minutes. When the setting is selected and thus displayed, you can set (change) its value. This is done by turning the Set Knob. You set the value of the setting using the Set Knob by turning it counterclockwise to decrease the value or clockwise to increase the value. The Set Knob is labeled with arrows pointing to the words DECREASE and INCREASE to show which way to turn. The display of the setting's value will change as you turn the Set Knob. Just keep turning until you see the value of the setting that you want.

### EXAMPLE

For example, say you turn the Select Knob to point to the PUMP DURATION setting and the display shows :10. You have selected the PUMP DURATION setting and this setting presently has a value of 10 minutes. The pump will stay on for 10 minutes each time it turns on. Say you want to make it stay on for 15 minutes instead. Turn the Set Knob (not the Select Knob) in the INCREASE direction (see the arrows around the knob) until you see :15. As you turn the Set Knob, each time it clicks the display will change. The first click will make the display show :11, the new value of the PUMP DURATION setting. The next click will show :12, and so on until you see :15. You have now set the value of the PUMP DURATION setting to 15 minutes.

### USING A NEW SETTING

While you have been turning knobs and looking at the display, the Plant Pro has been busy controlling your lamp and pump and so on. To avoid confusing the Plant Pro while you make changes to the value of a setting, the Plant Pro continues operating using the old values of all the settings. These old values are the ones it was using when you turned the Select Knob from pointing to RUN to point to the PUMP DURATION setting (or to point to anything else other than RUN). Although you changed the value of the PUMP DURATION setting to 15 minutes, the Plant Pro is still using the old value of the PUMP DURATION setting which was 10 minutes. So, to get the Plant Pro to use the new value you turn the Select Knob back to RUN. This tells the Plant Pro that you are satisfied with the changes and that the new values of the settings can be used. Remember, when you changed the value of the PUMP DURATION setting from 10 minutes, the first click changed it to 11 minutes. But that was not what you wanted. You kept turning the Set Knob until you saw what you wanted, 15 minutes. Only then do you turn the Select Knob to RUN to tell the Plant Pro to use 15 minutes for the PUMP DURATION. With the Select Switch pointing to RUN the Plant Pro will now use the new values of any settings that have been changed. You can change the values of several different settings before going back to RUN. When you go back to RUN, the Plant Pro will also save these new values in case the power goes out. They will be used again when the power comes back on.

## DIFFERENCES FROM EQUIPMENT WITH ONE KNOB PER SETTING

The Plant Pro is simpler to use than many other devices where you have a knob for each setting. Those kind of devices can have pretty crowded front panels. There is usually no separate display of the setting. You find the knob for the setting of interest. You then turn that knob until the knob's pointer matches up with lines and numbers around the knob. To change another setting, find another knob.

On the Plant Pro, there are only two knobs (and a display) to handle all the settings. The Set Knob only changes the value of the setting you have selected with the Select Knob. This is the setting that is being displayed. Plant Pro "remembers" the values of the settings that are not being selected. When you turn the Select Knob to show a setting, the value you last set that particular setting to with the Set Knob will be displayed. The Plant Pro cares about what the Select Knob is pointing to. It uses that position to decide what setting you want to view and possibly change. However, Plant Pro *does not care* about the actual position of the Set Knob. All that matters is when you turn the Set Knob a click in the INCREASE or DECREASE direction. When you do that, Plant Pro increases or decreases only the setting that the Select Knob is pointing to and is thus being displayed. When you select a different setting with the Select Knob, the Plant Pro shows the last value of this different setting. You can then increase or decrease the value of this setting by turning the Set Knob. It doesn't matter what position the Set Knob was in due to the previous setting.

## GENERAL OPERATION ISSUES

### POWER ON

At power on all the displays will be lit for one second. All outlets will be off during this second. Then the display will start flashing. All settings (including RUN mode) being used before power was lost will be restored. The clock will start with the minutes at :00 and the hours at the last value before power was lost. Operation will then begin. Set the time as indicated in **Setting The Clock** (page 19) to stop the flashing. If the display continues to flash after that, then see **Faults** (page 40). Sensor readings will rise until they reach their stable values after power on. If the display remains off, it may be because of a RUN setting where the display is blanked at night. See **Display Blanking At Night** (page 21).

### INDICATORS

When the Select Knob has selected a given setting, for most settings an appropriate indicator will light up. If you select the PUMP DURATION setting, the colon (":") will light up. This tells you a time value is being displayed. Other settings may have a different indicator lit. For example, if you select the FAN MAX TEMPERATURE setting then the °F indicator will light. This tells you that the value of the FAN MAX TEMPERATURE setting is shown in degrees Fahrenheit.

### SPECIAL CASE VALUES

Normally the display shows numbers. However, some settings allow "special case" values. For example, if there is no Photocell Sensor connected, the PHOTOCCELL setting should be set to the value "nonE". Although the display is best for showing numbers, for such letters it will do. Each setting description explains any special case values and how to set them. Special case values are accessed at a roll-over/roll-under region or beyond a maximum as appropriate. The special case values used are "nonE" (for the sensor settings), plus "PCon" and "PCLn" for the lamp. Also, in CO2 Sensor Mode, some values will be displayed as "CO2".

## CLOCK

### OVERVIEW

The Plant Pro has a digital clock to keep time. The clock is used to help decide when to turn things on or off. Some actions can be set to happen at a specific time. For example, the LAMP START setting tells the Plant Pro the time to turn on the lamp. Other actions can be set to last for a number of hours or minutes. For example, the LAMP DURATION setting tells the Plant Pro how many hours to leave the lamp on. The clock is configured at the factory to operate in one of two modes for showing time. These two modes are 12 Hour AM/PM Mode and 24 Hour Mode and are described below.

## COLON

When ever hours or minutes are shown the colon is lit. When the display shows the clock with the present time, the colon will flash every second. If hours or minutes for some setting are being shown then the colon will be on but not flashing.

## 12 HOUR AM/PM MODE

The 12 hour format with AM and PM indication is common in some countries. In 12 hour AM/PM mode only, when the clock, SET HOURS, SET MINUTES, or LAMP START is shown, AM or PM will be indicated. For example, when showing the LAMP START setting (the time of day to turn on the lamp) the AM or PM indicator will be lit. When a setting that tells the number of hours or minutes for something to continue is being shown, AM or PM is not relevant and will not be indicated. For example, when showing the LAMP DURATION setting (the number of hours the lamp should stay on) the AM and PM indicators will not be lit. In the 12 Hour AM/PM Mode, the Plant Pro keeps time from 12:00 AM (midnight) to 11:59 AM (1 minute before noon) to 12:00 PM (noon) to 11:59 PM (1 minute before midnight) and then back to 12:00 AM (midnight) and so on.

## 24 HOUR MODE

The 24 hour format is popular in many countries and most military organizations. This has no AM and PM indication. In this mode, the AM and PM indicators are never lit. In the 24 Hour Mode the Plant Pro keeps time from 00:00 (midnight) to 11:59 (1 minute before noon) to 12:00 (noon) to 23:59 (1 minute before midnight) and then back to 00:00 (midnight).

## ROLL-OVER/UNDER

Values which naturally roll-over or roll-under (like time of day) can be adjusted accordingly. For example, with the SET HOURS setting, turning the Set Knob in the INCREASE direction the display will roll-over from 11:00 PM (23:00) to 12:00 AM (00:00). Turning the Set Knob in the DECREASE direction will do the reverse, it will roll-under from 12:00 AM (00:00) to 11:00 PM (23:00). Values which have maximums or minimums will not. For example, with the PUMP DURATION setting, turning the Set Knob in the INCREASE direction from :60 will not make the display get bigger nor go back to :00. This is because 60 minutes is the maximum for the PUMP DURATION setting. You have to turn the Set Knob in the DECREASE direction to make PUMP DURATION smaller and eventually get back to :00.

## SETTING THE CLOCK

The clock is always running. If you move the Select Knob away from RUN, perhaps to change a sensor value, the clock will still keep the time. The only thing that will change the clock is if the SET TIME HOURS or SET TIME MINUTES settings are changed. Although the clock continues to keep time, the values for SET TIME HOURS and SET TIME MINUTES are stopped. SET TIME HOURS and SET TIME MINUTES stay at the time the clock was when you moved from RUN. Now if you change the time using these settings, the clock will be updated with the changed setting(s) when you move the switch back to the RUN position. If you change SET TIME HOURS then the clock's hours are given the new value you set. If you change SET TIME MINUTES then the clock's minutes are given the new value you set. Note that the internal (not displayed) seconds count is set to :00 if SET TIME MINUTES is changed. This allows you to synchronize the Plant Pro's clock with another timepiece or telephone time.

If you don't want to change the time, just don't change the values of SET TIME HOURS and SET TIME MINUTES. Plant Pro will see that these values haven't been changed and ignore them. It won't change the clock back to the old time in these settings.

STEP	SELECT KNOB	SET KNOB
1	SET HOURS	Turn to show the correct hours. If the correct hours show but not the correct AM or PM, keep turning until all are correct. Although the minutes are displayed, the Set Knob will not change them.
2	SET MINUTES	Turn to show the correct minutes. Although the hours are displayed, the Set Knob will not change them.
3	RUN	Now the new settings will be used.

## **RUN**

### **OVERVIEW**

After changing settings, the new values are used only when the Select Knob is moved to RUN. The system continues to operate normally with the old settings until then. If you are just changing one setting, then switch to RUN after making it. If you are going to make changes to more than one setting, you can also make all the changes first and then select RUN. Except when changing the settings, the Select Knob should be left in the RUN position. When the Select Knob is moved to RUN, settings are saved for use after a power outage. When the Select Knob points to RUN, the time and actual sensor values can be displayed. The display can also be made to be blanked at night.

### **SETTINGS VERSUS ACTUAL VALUES**

When setting sensor related values, the setting will be displayed. This is the value that the system will try to maintain. During RUN, the actual value read by the sensor will be displayed. For example, you might want the vent fan to turn on if the temperature is above 85°F. You turn the Select Knob to select the FAN MAXIMUM TEMPERATURE setting. The value of the FAN MAXIMUM TEMPERATURE setting is now displayed. You now turn the Set Knob until the desired value of 85°F is displayed. You then turn the Select Knob to RUN. Now the Plant Pro uses the new setting value. Now that the Select Knob is turned to RUN, the display can show the actual temperature measured by the Temperature Sensor. If the room is actually 78°F, then this will be displayed. This lets you see what the temperature of your grow area is at a glance. There are various display modes for viewing sensor values.

### **DISPLAY MODES**

When the Select Switch is in the RUN position, the display can be made to show the status of any of the sensors or the clock by turning the Set Knob. In addition it can be made to rotate (alternate) between them so you can see the status of the entire installed system at a glance. The display can also be made to be blanked at night. Each position of the Set Knob in the INCREASE direction will set the next type of display. DECREASE will show the previous. This only affects the display when in the RUN position. If the Select Knob is moved to some other position, the setting selected by the Select Knob will be shown as expected. When the Select Knob is returned to RUN, the display will continue in the previously set mode. The display modes are as follows.

### **ROTATE (ALTERNATE) THE DISPLAY MODE**

This will show the time and then sensors. Enabled sensors are the ones where their related setting is something other than "nonE". The Photocell sensor will not be shown if its related setting is "nonE". The other sensors will always be displayed, independent of their setting. This allows these sensors to be displayed even if they are not being used for control and thus is not enabled. The sequence is clock, Temperature Sensor, Humidity Sensor, CO2 Sensor, and (if enabled) Photocell Sensor. Each display is shown for 2 seconds, then the next one is shown for 2 seconds, and so on. After the last, the sequence repeats. Each display has a different indicator lit to tell what is being displayed. Each display is the same as the one in the Fixed Display mode.

## FIXED DISPLAY MODES

In these modes the display remains fixed on a single item. It does not rotate (alternate) between various displays. The Photocell Sensor will be displayed independent of its setting.

MODE	SHOWS	INDICATOR
Clock	Present time according to the clock.	Colon flashes every second. For 12 hour AM/PM mode only, AM or PM will be on.
Temperature	Actual temperature as measured by the Temperature Sensor.	The °F indicator will be on.
Humidity	Actual humidity as measured by the Humidity Sensor.	The rH indicator will be on.
CO2	Actual CO2 PPM level as measured by the CO2 Sensor.	The PPM indicator will be on.
Photocell	Actual light level as measured by the Photocell Sensor.	The PHOTO indicator will be on.

## DISPLAY BLANKING AT NIGHT

Display Blanking At Night is used by those extremely concerned about any light at night, even the Plant Pro's display. Night is when the Plant Pro's lamp is off, and in photocell modes, when there is no natural light either. This mode is similar to the first mode of alternating displays every 2 seconds. During the day the display operates in the same manner except the decimal point of the right most digit will be on. At night, the display is completely off - including that decimal point. If power is interrupted, the normal 1 second all displays on at power on will not occur. If a fault occurs, the display will flash during the day but remain off at night. If the user changes the Select Knob from RUN or changes the Set knob in the DECREASE direction to choose a different Run mode, then the display will come back on as usual.

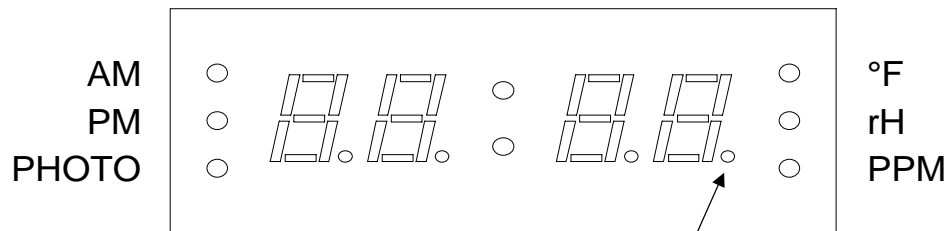

THIS DECIMAL POINT IS ON DURING THE DAY IN THIS MODE

## SETTING THE RUN DISPLAY

STEP	SELECT KNOB	SET KNOB
1	RUN	Turn 6 or more "clicks" in the DECREASE direction to automatically rotate (alternate) between displays every 2 seconds.
2	RUN	Turn 1 click in the INCREASE direction to show the clock.
3	RUN	Turn 1 click in the INCREASE direction to show the temperature.
4	RUN	Turn 1 click in the INCREASE direction to show the humidity
5	RUN	Turn 1 click in the INCREASE direction to show the CO2 level.
6	RUN	Turn 1 click in the INCREASE direction to show the photocell level.
7	RUN	Turn 1 click in the INCREASE direction to automatically rotate (alternate) between displays every 2 seconds during the day. The decimal point of the rightmost digit will be on. At night the display will be off.

## LAMP

### OVERVIEW

The lamp can be operated in any of four modes. Time Clock Mode is the simplest. This section describes operating the lamp in Time Clock Mode. The remaining three lamp modes rely on the Photocell Sensor to determine sunrise and sunset. If you are using sunlight or a separately controlled lighting system, then you can skip this section on the lamp because you will want to use one of the Photocell Modes. See **Photocell Modes** (page 29).

Time Clock Mode is used when there is no Photocell Sensor and the sun is ignored. The lamp turns on once a day at the time you set. It stays on for the number of hours you set. It then turns off until the next day. CO2 is off when the lamp is off. In typical operation the pump is off when the lamp is off but there are other options. The vent fan is also affected but in a different way. See **Pump** (page 23) and **Fan and CO2** (page 24) for details. The settings to control the lamp are LAMP START and LAMP DURATION.

### THE LAMP START SETTING

The LAMP START setting tells the Plant Pro the time of day to turn on the lamp. Only the hours can be set. The lamp starts at the beginning of the hour, that is, when the minutes are at :00. Other than that limitation, any time can be set, such as 7:00 AM or 5:00 PM. When turning the Set Knob in the INCREASE direction, when it gets to 11:00 AM it next shows 12:00 PM (noon). It then continues through the day. When it gets to 11:00 PM it next shows "PCon" and then "PCLn". These two are special case values used in Photocell Modes and should not be used in Time Clock Mode. After "PCLn" it next shows 12:00 AM (midnight). It then continues through the morning to 11:00 AM and continues as described above. By turning the Set Knob in the DECREASE direction, the reverse will happen.

### THE LAMP DURATION SETTING

The LAMP DURATION setting tells the Plant Pro how long to leave the lamp on once it starts. It can be from 0 to 24 hours. Only the hours can be set. When setting the LAMP DURATION, AM or PM is not indicated because it doesn't apply. When the Set Knob is turned in the DECREASE direction, it eventually shows 00:00. Even though the knob can still be turned in that direction, the number won't get any smaller. When LAMP DURATION is set to 00:00 the lamp will always be off. When the Set Knob is turned in the INCREASE direction, it eventually shows 24:00. When LAMP DURATION is set to 24:00 the lamp will always be on. Turning further, it next shows "PCon" and then will change no more. This is a special case value used in Photocell Modes and should not be used in Time Clock Mode.

## SETTING THE LAMP

STEP	SELECT KNOB	SET KNOB
1	LAMP START	Turn to show the time to turn on the lamp. If the correct hours show but not the correct AM or PM, keep turning until all are correct Do not set to "PCon" or "PCLn".
2	LAMP DURATION	Turn to show the number of hours for the lamp to remain on. If the lamp is to be always on, set to 24:00. Do not set to "PCon".
3	PHOTOCELL	Turn in the INCREASE direction until "nonE" shows. This tells the Plant Pro to ignore the Photocell Sensor, whether connected or not.
4	RUN	Now the new settings will be used. If the display starts to flash, see <b>Faults</b> (page 40).

## **PUMP**

### OVERVIEW

In typical operation the pump is off when the lamp is off but there are other options. The description below assumes this default Pump Mode and that the lamp is in Time Clock Mode. In Photocell Modes the pump is also affected by the sun. See **Photocell Modes** (page 29) for details. When the lamp first turns on, the pump will turn on for the number of minutes that you set with the PUMP DURATION setting. The pump then turns off. It then repeats this at intervals you set with PUMP INTERVAL. This continues as long as the lamp is on. See **Options** (page 29) for advanced Pump Modes including night time pumping and aeroponics.

### THE PUMP INTERVAL SETTING

The PUMP INTERVAL setting tells the Plant Pro how often to turn on the pump when the lamp is on. It can be from 1 to 24 hours. Only the hours can be set. The pump starts at the beginning of the hour, that is, when the minutes are at :00. When setting the PUMP INTERVAL, AM or PM is not indicated because it doesn't apply. When the Set Knob is turned in the DECREASE direction, it eventually shows 1:00. Even though the knob can still be turned in that direction, the number won't get any smaller. When the PUMP INTERVAL is set to 1:00 the pump will turn on every hour when the lamp is on. If set to 2:00, it will turn on every two hours, that is, every other hour. When the Set Knob is turned in the INCREASE direction, it eventually shows 24:00. When the PUMP INTERVAL is set to 24:00 the pump will turn on one time when the lamp turns on. It will not turn on again until the lamp turns on the next day.

### THE PUMP DURATION SETTING

The PUMP DURATION setting tells the Plant Pro how long to leave the pump on once it starts. It can be from 0 to 60 minutes. Only the minutes can be set. When setting the PUMP DURATION, AM or PM is not indicated because it doesn't apply. When the Set Knob is turned in the DECREASE direction, it eventually shows :00. Even though the knob can still be turned in that direction, the number won't get any smaller. When the PUMP DURATION is set to :00 the pump will always be off. When the Set Knob is turned in the INCREASE direction, it eventually shows :60. Even though the knob can still be turned in that direction, the number won't get any larger. When the PUMP DURATION is set to :60 the pump will stay on until the beginning of the next hour. If the PUMP INTERVAL is set to 1:00 and the PUMP DURATION is set to :60, then the pump will always be on when the lamp is on.

STEP	SELECT KNOB	SET KNOB
1	PUMP INTERVAL	Turn to show the number of hours between pump cycles. Set to 1:00 to turn on at the beginning of every hour the lamp is on, 2:00 for every other hour, and so on.
2	PUMP DURATION	Turn to show the number of minutes for the pump to be on in each pump cycle.
3	RUN	Now the new settings will be used.

## FAN AND CO2

### OVERVIEW

The Plant Pro lets you control a vent fan and CO2 dispensing equipment. Discussion of CO2 assumes you have CO2 dispensing equipment plugged into the CO2 outlet on the front panel of the Plant Pro. This equipment could be a solenoid valve to release bottled CO2 or a CO2 generator. Of course, the Plant Pro can control a vent fan alone if you have no such CO2 dispensing equipment. The operation of the lamp, vent fan and CO2 are related. The CO2 will stay off when the lamp is off because plants can only make use of CO2 while there is light for photosynthesis. The vent fan and CO2 are never on at the same time because the vent fan would remove the CO2 from the growing area before the plants had a chance to use it. So the vent fan is always off while CO2 is being dispensed. This Fan and CO2 section assumes the lamp is in Time Clock Mode. In Photocell Modes the vent fan and CO2 are also affected by the sun as sensed by the Photocell Sensor. See **Photocell Modes** (page 29) for details. The vent fan and the CO2 are also affected by the Temperature and Humidity Sensors. Temperature, Humidity, and CO2 Sensors can be independently disabled if not present by setting their values to "nonE". There are two CO2 dispensing modes. Use the CO2 Timed Mode if you do not have a CO2 Sensor. Use the CO2 Sensor Mode if you do have a CO2 Sensor. If you have no CO2 dispensing equipment at all, then use the CO2 Timed Mode set up to dispense no CO2. The settings to control the vent fan and CO2 are FAN MAX TEMPERATURE, FAN MAX HUMIDITY, FAN CO2 DELAY, CO2 PPM, CO2 INTERVAL, and CO2 DURATION. See **Options** (page 29) for advanced Fan Modes and Sensor Offset Modes. These include alternative night time vent fan operation and adjustable offsets for the temperature, humidity and CO2 sensors. The discussion below assumes the default modes.

### CO2 TIMED MODE

Use CO2 Timed Mode when there is no CO2 Sensor. The CO2 Timed Mode releases CO2 according to a time schedule you set. You set how often (CO2 INTERVAL) and how long (CO2 DURATION) you want CO2 released. You also set how long to hold the vent fan off (FAN CO2 DELAY) after CO2 has been released. This will give the plants extra time to absorb CO2 before it is removed by the vent fan. To use CO2 Timed Mode you must first defeat CO2 Sensor Mode. To disable the CO2 Sensor (and thus defeat CO2 Sensor Mode), you set the value of the CO2 PPM setting to "nonE".

If you don't have CO2 dispensing equipment, set CO2 INTERVAL to 5 minutes, CO2 DURATION to 0 minutes, and FAN CO2 DELAY to 0 minutes, the minimum values they can all be set. The vent fan will run when ever needed due to excess temperature or humidity.

The CO2 INTERVAL setting can have a value of 5, 10, 15, 20, 30 or 60 minutes. A CO2 cycle starts at the beginning of each interval. From 1 to 12 CO2 cycles can occur during each hour. For example, say CO2 INTERVAL is set to 10 minutes, CO2 DURATION is set to 2 minutes, and FAN CO2 DELAY is set to 3 minutes. There will be 6 CO2 cycles per hour, starting at :00, :10, and so on through :50 and then repeating the next hour. In the second cycle, the CO2 would turn on and the vent fan off at :10 because the CO2 INTERVAL setting has a value of 10 minutes. The CO2 would turn off at :12 because the CO2 DURATION setting is 2 minutes and the CO2 has been on for 2 minutes. The vent fan could come on if needed (due to temperature or humidity) at :15 because the FAN CO2 DELAY setting is 3 minutes and the CO2 has been off for 3 minutes. At :20 the next cycle would start, the vent fan would turn off, the CO2 on, and the process would be repeated. For each of the different CO2 INTERVAL settings, the following table shows the start time of the 1st cycle, 2nd cycle, and so on in each hour.

CO2 INTERVAL	CO2 CYCLES AND THEIR START TIME											
	:00	:05	:10	:15	:20	:25	:30	:35	:40	:45	:50	:55
5	1st	2nd	3rd	4th	5th	6th	7th	8th	9th	10th	11th	12th
10	1st		2nd		3rd		4th		5th		6th	
15	1st			2nd			3rd			4th		
20	1st				2nd				3rd			
30	1st						2nd					
60	1st											

When a CO2 cycle starts, the CO2 outlet is turned on and the vent fan is kept off independent of temperature or humidity. After CO2 DURATION minutes have elapsed, the CO2 outlet is turned off and the FAN CO2 DELAY period starts. During this time neither CO2 nor vent fan are on. This gives the plants extra time to absorb CO2 before it is removed by the vent fan. You need to judge for yourself, based on your particular plants and growing environment, how long of a delay is practical. Usually plants can withstand higher temperatures in a CO2 rich environment. In general you would estimate how long it usually takes to reach this higher temperature with no vent fan and use that time to set the FAN CO2 DELAY value. With a little trial and error a practical delay time can be arrived at. Properly implementing the FAN CO2 DELAY setting should make the relatively expensive bottled CO2 last longer with improved yields. After FAN CO2 DELAY minutes have elapsed, the vent fan can turn on depending on its related sensors. It will turn on if the temperature goes above the FAN MAX TEMPERATURE or the humidity goes above the FAN MAX HUMIDITY. It will also turn on if both of the above are set to "nonE" and thus both sensors are not enabled. The vent fan can turn on or off as often as needed during this period. It cannot turn on during the CO2 DURATION or FAN CO2 DELAY periods because CO2 takes precedence over the vent fan. Based on the CO2 INTERVAL setting, the CO2 cycle will eventually end. The vent fan is turned off. A new CO2 cycle then begins as above. If the CO2 INTERVAL is shorter than the CO2 DURATION then there will be no FAN CO2 DELAY period and the CO2 will remain on. This should be avoided because then the vent fan can never turn on. If the CO2 INTERVAL is shorter than the total of the CO2 DURATION and FAN CO2 DELAY then there will be a short FAN CO2 DELAY period. This should also be avoided because still the vent fan can never turn on. In general, these three values need to be adjusted to allow enough time for the vent fan to control the temperature. The vent fan will also run depending on the Temperature and Humidity Sensors when the lamp is off and therefore no CO2 cycle is running.

## CO2 SENSOR MODE

If you have a CO2 Sensor, such as the Solatel CO2 Sensor, you will want to use this mode because of the CO2 automation it offers. When this sensor is attached, the Plant Pro maintains a CO2 level in PPM that you select. It will release CO2 into the garden as needed to maintain this level. You defeat the CO2 Timed Mode and select the desired CO2 concentration in PPM you wish to maintain in your garden all in one easy step by changing the value of the CO2 PPM setting to your desired concentration. In CO2 Sensor Mode the needs for ventilation (vent fan), based on measurements by the Temperature and Humidity Sensors, take precedence over CO2 dispensing because high temperature and humidity can damage plants. The vent fan must be able to keep temperature and humidity under the maximum values you have set in order for CO2 to be dispensed in the CO2 Sensor Mode. If not, the vent fan will always be on and the CO2 will always be off. In any case, the vent fan and CO2 are never on at the same time (which would waste CO2).

In the CO2 Sensor Mode the CO2 PPM setting is some value other than "nonE" and the CO2 Sensor is thus enabled. In CO2 Sensor Mode the vent fan takes precedence over the CO2 dispensing. The settings for CO2 INTERVAL and CO2 DURATION are ignored and are shown on the display as "CO2 ". If the temperature and humidity are below their settings and not in need of vent fan operation, the CO2 outlet is on when the CO2 actual value is below the CO2 PPM setting and turns off when the CO2 actual value is above the CO2 PPM setting.

Time is ignored with the exception of the FAN CO2 DELAY. You set how long to hold the vent fan off (FAN CO2 DELAY) after CO2 has been released. This will give the plants extra time to absorb CO2 before it is removed by the vent fan. The Plant Pro keeps track of how long the CO2 has been off, whether it was shut off because of high CO2 (no more CO2 demand) or because of high temperature or humidity (ventilation demand). When the temperature or humidity becomes high based on the FAN MAX TEMPERATURE or FAN MAX HUMIDITY setting, if the CO2 is on, it is shut

off, independent of the CO2 PPM setting. The Plant Pro then compares the FAN CO2 DELAY setting to how long the CO2 has been off. When the CO2 has been off long enough, the vent fan turns on. The fan remains on until both temperature and humidity become low. At that point the CO2 will turn on if the CO2 level is low based on the CO2 setting. If the CO2 had been off before the temperature or humidity went high, that time is taken into account for the delay. Thus if the CO2 had already been off for the FAN CO2 DELAY setting or longer, the fan would turn on immediately when temperature or humidity went high. For user's who want the Plant Pro to operate with no delay, simply set the FAN CO2 DELAY setting to 0. Because of synchronization issues between the Plant Pro's clock and when temperature or humidity go high, the actual delay can vary by one second from the FAN CO2 DELAY setting.

If the FAN MAXIMUM TEMPERATURE or FAN MAXIMUM HUMIDITY is set to nonE, the related sensor will be ignored and cannot affect CO2 dispensing or fan operation. However, if both of the above are set to nonE and thus both sensors are not enabled, then it will be interpreted as a continuous demand for the fan. This should be avoided in CO2 Sensor Mode as the CO2 can thus never turn on.

For all examples below, FAN CO2 DELAY setting is 3 minutes.

CO2 is on because the CO2 level is low. Temperature or humidity goes high. CO2 turns off. Three minutes later the fan turns on. For the 3 minute delay, all 3 minutes were after temperature or humidity went high.

CO2 is off. It has been off for 30 seconds because the CO2 level is high. Temperature or humidity goes high. 2 minutes 30 seconds later the fan turns on. For the 3 minute delay, 30 seconds were before temperature or humidity went high and 2 minutes 30 seconds were after.

CO2 is off. It has been off for 4 minutes because the CO2 level is high. Temperature or humidity goes high. The fan turns on immediately. For the 3 minute delay, all 3 minutes (and more) were before temperature or humidity went high.

## THE FAN MAX TEMPERATURE SETTING

The Plant Pro will turn on the vent fan to remove heat from the growing area if the temperature is higher than the FAN MAX TEMPERATURE setting, depending on the Humidity Sensor and the CO2 Mode as described above. FAN MAX TEMPERATURE can be set from 0 to 110 °F (degrees Fahrenheit). The °F indicator will light when FAN MAX TEMPERATURE is shown. When the Set Knob is turned in the DECREASE direction, FAN MAX TEMPERATURE eventually shows 0. Even though the knob can still be turned in that direction, the number won't get any smaller. When the FAN MAX TEMPERATURE is set to 0 the vent fan will always be on because the temperature can never get below this. When the Set Knob is turned in the INCREASE direction, FAN MAX TEMPERATURE eventually shows 110. FAN MAX TEMPERATURE can not be set to a temperature higher than 110. When the FAN MAX TEMPERATURE is set to 110, unless the vent fan is on due to humidity, the vent fan will always be off because the temperature can never get above 110. Turning further, FAN MAX TEMPERATURE next shows "nonE" and then will change no more. A FAN MAX TEMPERATURE setting of "nonE" is a special case value which tells the Plant Pro that there is no Temperature Sensor and therefore the Temperature Sensor should be ignored. Do not set FAN MAX TEMPERATURE to "nonE" if there is a Temperature Sensor connected.

## THE FAN MAX HUMIDITY SETTING

The Plant Pro will turn on the vent fan to remove humid air from a grow area if the humidity is higher than the FAN MAX HUMIDITY setting, depending on the Humidity Sensor and the CO2 Mode as described above. FAN MAX HUMIDITY can be set from 0 to 100 rH (relative humidity). The rH indicator will light when FAN MAX HUMIDITY is shown. When the Set Knob is turned in the DECREASE direction, FAN MAX HUMIDITY eventually shows 0. Even though the knob can still be turned in that direction, the number won't get any smaller. When the FAN MAX HUMIDITY is set to 0 the vent fan will always be on because the humidity can never get below 0. When the Set Knob is turned in the INCREASE direction, FAN MAX HUMIDITY eventually shows 100. FAN MAX HUMIDITY cannot be set to a humidity higher than 100. When the FAN MAX HUMIDITY is set to 100, unless the vent fan is on due to temperature, the vent fan will always be off because the humidity can never get above 100. Turning further, FAN MAX HUMIDITY next shows "nonE" and then will change no more. A FAN MAX HUMIDITY setting of "nonE" is a special case value which tells the Plant Pro that there is no Humidity Sensor and therefore the Humidity Sensor should be ignored. Do not set FAN MAX HUMIDITY to "nonE" if there is a Humidity Sensor connected.

## THE FAN CO2 DELAY SETTING

The FAN CO2 DELAY setting is used in both CO2 Timed Mode and CO2 Sensor Mode although there are some restrictions when used in the former. FAN CO2 DELAY tells the Plant Pro how many minutes to wait after the CO2 turns off before turning on the vent fan. FAN CO2 DELAY can be from 0 to 60 minutes. When setting this, AM or PM is not indicated because it doesn't apply. In CO2 Timed Mode the total of the CO2 DURATION and FAN CO2 DELAY should be shorter than the CO2 INTERVAL to allow the vent fan to turn on if needed. When the Set Knob is turned in the DECREASE direction, FAN CO2 DELAY eventually shows :00. Even though the knob can still be turned in that direction, the number won't get any smaller. When FAN CO2 DELAY is set to :00 there will be no delay and the vent fan can turn on immediately when the CO2 turns off. When the Set Knob is turned in the INCREASE direction, FAN CO2 DELAY eventually shows :60. Even though the knob can still be turned in that direction, the number won't get any larger. In CO2 Timed Mode, if FAN CO2 DELAY is set to :60 the vent fan can never turn on and therefore should not be used.

## THE CO2 PPM SETTING

In using the CO2 Timed Mode be sure to defeat the CO2 Sensor Mode by setting CO2 PPM to "nonE". Any other value is used only in CO2 Sensor Mode when you have a CO2 Sensor connected. The Plant Pro will turn on the CO2 tank or generator if the CO2 level is less than CO2 PPM setting, the lamp is on, and there is no demand for the vent fan due to high temperature or humidity. CO2 PPM can be set from 0 to 2000 PPM (parts per million CO2 concentration). The CO2 PPM value steps by 10 PPM. The PPM indicator will light when CO2 PPM is shown. When the Set Knob is turned in the DECREASE direction, CO2 PPM eventually shows 0. Even though the knob can still be turned in that direction, the number won't get any smaller. When CO2 PPM is set to 0 the CO2 tank or generator will never be on because the CO2 level can never get below 0. If the Set Knob is turned in the INCREASE direction one position, then CO2 PPM will show 10, then 20, then 30, and so on until 2000. CO2 PPM can not be set to a CO2 level higher than 2000. When CO2 PPM is set to 2000, unless there is demand for the vent fan due to high temperature or humidity, the CO2 tank or generator will always be on because the CO2 level can never get above 2000. Turning further, CO2 PPM next shows "nonE" and then will change no more. A CO2 PPM setting of "nonE" is a special case value which tells the Plant Pro that there is no CO2 Sensor and therefore the CO2 Sensor should be ignored. This puts the system in CO2 Timed Mode and is not used in CO2 Sensor Mode.

## THE CO2 INTERVAL SETTING

In CO2 Sensor Mode the CO2 INTERVAL setting always displays "CO2 " and has no effect on operation. The CO2 INTERVAL setting is used only in CO2 Timed Mode. The CO2 INTERVAL setting tells the Plant Pro how often to turn on the CO2 tank or generator when the lamp is on. It can be 5, 10, 15, 20, 30 or 60 minutes. Only these values can be set. Hours can not be set either. When setting CO2 INTERVAL, AM or PM is not indicated because it doesn't apply. The CO2 cycle starts at the beginning of the hour, that is, when the minutes are at :00. Another cycle then starts after the number of minutes set. Therefore there can be 12, 6, 4, 3, 2 or 1 cycles per hour. For example, if CO2 INTERVAL is set to 15 minutes, then there will be 4 cycles per hour, starting at :00, :15, :30, and :45, and then repeating the next hour at :00. The total of the CO2 DURATION and FAN CO2 DELAY should be shorter than the CO2 INTERVAL to allow the vent fan to turn on if needed. When the Set Knob is turned in the DECREASE direction, CO2 INTERVAL eventually shows :05. Even though the knob can still be turned in that direction, the number won't get any smaller. When CO2 INTERVAL is set to :05 the CO2 will turn on every 5 minutes (12 times per hour) when the lamp is on. When the Set Knob is turned in the INCREASE direction, it will show :10, then :15, then :20, then :30 and finally :60. Even though the knob can still be turned in that direction, the number won't get any larger. When CO2 INTERVAL is set to :60 the CO2 will turn on one time each hour the lamp is on at :00. It will not turn on again until :00 in the next hour.

## THE CO2 DURATION SETTING

In CO2 Sensor Mode the CO2 DURATION setting always displays "CO2 " and has no effect on operation. The CO2 DURATION setting is used only in CO2 Timed Mode as described below. CO2 DURATION tells the Plant Pro how long to leave the CO2 tank or generator on once it starts. CO2 DURATION can be from 0 to 60 minutes. Only the minutes can be set. When setting CO2 DURATION, AM or PM is not indicated because it doesn't apply. The total of the CO2 DURATION and FAN CO2 DELAY should be shorter than the CO2 INTERVAL to allow the vent fan to turn on if needed. When the Set Knob is turned in the DECREASE direction, CO2 DURATION eventually shows :00. Even though the knob can still be turned in that direction, the number won't get any smaller. When CO2 DURATION is set to

:00 the CO2 will always be off. The value of :00 should be used when there is no CO2 dispensing equipment present. When the Set Knob is turned in the INCREASE direction, CO2 DURATION eventually shows :60. Even though the knob can still be turned in that direction, the number won't get any larger. When CO2 DURATION is set to :60 the CO2 will always be on. This will not allow the vent fan to turn on and should not be used.

### SETTING THE VENT FAN WHEN NO CO2 DISPENSING EQUIPMENT IS PRESENT

STEP	SELECT KNOB	SET KNOB
1	FAN MAX TEMPERATURE	Turn to show the desired maximum growing area temperature. The vent fan will turn on when the actual temperature is above this, off when below. Do not set to "nonE"
2	FAN MAX HUMIDITY	If no Humidity Sensor is connected, turn in the INCREASE direction until "nonE" shows. If one is connected, turn to show the desired maximum growing area humidity. The vent fan will turn on when the actual humidity is above this, off when below.
3	CO2 PPM	Turn in the INCREASE direction until "nonE" shows. This tells the Plant Pro to ignore the CO2 Sensor and use CO2 Timed Mode
4	FAN CO2 DELAY	Turn in the DECREASE direction until :00 shows.
5	CO2 INTERVAL	Turn in the DECREASE direction until :05 shows.
6	CO2 DURATION	Turn in the DECREASE direction until :00 shows.
7	RUN	Now the new settings will be used.

### SETTING CO2 TIMED MODE WHEN CO2 DISPENSING EQUIPMENT IS PRESENT

STEP	SELECT KNOB	SET KNOB
1	FAN MAX TEMPERATURE	Turn to show the desired maximum garden temperature. The vent fan will turn on when the actual temperature is above this, off when below. The vent fan will not come on if the CO2 is on or during Fan CO2 Delay. Do not set to "nonE"
2	FAN MAX HUMIDITY	If no Humidity Sensor is connected, turn in the INCREASE direction until "nonE" shows. If one is connected, turn to show the desired maximum garden humidity. The vent fan will turn on when the actual humidity is above this, off when below. The vent fan will not come on if the CO2 is on or during Fan CO2 Delay.
3	CO2 PPM	Turn in the INCREASE direction until "nonE" shows. This tells the Plant Pro to ignore the CO2 Sensor and use CO2 Timed Mode
4	FAN CO2 DELAY	Turn to show the number of minutes to wait between when the CO2 turns off and the vent fan can turn on.
5	CO2 INTERVAL	Turn to show the number of minutes between CO2 cycles.
6	CO2 DURATION	Turn to show the number of minutes for the CO2 to be on in each CO2 cycle.
7	RUN	Now the new settings will be used.

## SETTING CO2 SENSOR MODE

STEP	SELECT KNOB	SET KNOB
1	FAN MAX TEMPERATURE	Turn to show the desired maximum garden temperature. The vent fan turns on if the actual temperature is above this, off if below. The vent fan will not come on during Fan CO2 Delay. Do not set to "nonE"
2	FAN MAX HUMIDITY	If no Humidity Sensor is connected, turn in the INCREASE direction until "nonE" shows. If one is connected, turn to show the desired maximum garden humidity. The vent fan turns on if actual humidity is above this, off if below. The vent fan will not come on during Fan CO2 Delay.
3	CO2 PPM	Turn to show the desired CO2 level. The CO2 will turn on when the actual level is below this, off when above. The CO2 will not turn on if the fan is on or during Fan CO2 Delay. This tells the Plant Pro to use CO2 Sensor Mode. Do not set to "nonE"
4	FAN CO2 DELAY	Turn to show the number of minutes to wait between when the CO2 turns off and the vent fan can turn on.
5	CO2 INTERVAL	No need to turn. Step 3 causes this display to show "CO2".
6	CO2 DURATION	No need to turn. Step 3 causes this display to show "CO2".
7	RUN	Now the new settings will be used.

## OPTIONS

### INTRODUCTION

The OPTIONS setting allows a grower the ability to customize the Plant Pro to work in special growing situations. The default operating mode is the best for most growers. Most growers will want to operate the pump in the default mode which is on during the day based on the PUMP INTERVAL and PUMP DURATION settings and off at night. Special pump situations include the need for night time moisture cycles, 24 hour a day pumping, and aeroponics. Most growers will want the vent fan to operate in the default mode which is based on temperature and humidity whether day or night. Special vent fan situations include the need to disable the fan at night and/or do a timed fresh air cycle independent of temperature or humidity. Most growers will want temperature, humidity and CO2 control to operate in the default mode which switches the device on or off due to a small change in the sensor reading. Special sensor control situations include the need to allow a larger change in the sensor reading before switching the vent fan or CO2 equipment on or off.

Most settings for the Plant Pro require a large range of values. For example, FAN MAX TEMPERATURE can be set over the range 0-110. These settings are set separately using different positions on the Select Knob. There are 4 functions that can be set over a small range of only 4 values each. They are combined and set when the Select Knob points to OPTIONS. Each function is assigned a digit. Each function can be set to one of four modes with codes of 0 - 3. The functions are for special pump modes, special vent fan modes, temperature and humidity offsets, and CO2 offsets. Most growers will not need to change these but are provided for those with special needs. Review the 4 functions below. The code for each mode is listed at the left. The first mode (0) is the default in **BOLD** and is recommended by Solatel for most users. **WHEN IN DOUBT, USE 0.**

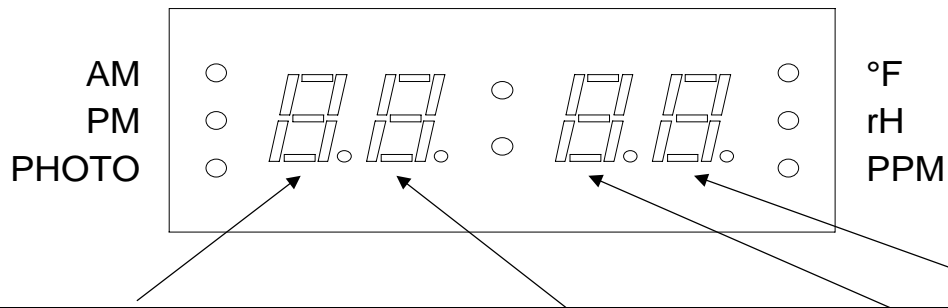

CODE	PUMP	VENT FAN	TEMPERATURE AND HUMIDITY OFFSET	CO2 OFFSET
0	DAY: On per settings. NIGHT: Off.	DAY: On due to temperature or humidity. NIGHT: On due to temperature or humidity.	1 °F, 1 %rH	10 PPM
1	DAY: On per settings. NIGHT: On 15 minutes at 12 AM, 6 AM, 12 PM, 6 PM (only if it is night).	DAY: On due to temperature or humidity. NIGHT: Off.	2 °F, 2 %rH	20 PPM
2	DAY: On per settings. NIGHT: On per settings.	DAY: On due to temperature or humidity. NIGHT: On due to temperature or humidity plus 5 minutes every hour.	3 °F, 3 %rH	50 PPM
3	DAY: On 1 minute every 4 minutes. NIGHT: On 1 minute every 4 minutes.	DAY: On due to temperature or humidity. NIGHT: On 5 minutes every hour.	4 °F, 4 %rH	100 PPM

## EXAMPLE

Say you wanted the following combination:

FUNCTION	PUMP	VENT FAN	TEMPERATURE AND HUMIDITY OFFSET	CO2 OFFSET
MODE	DAY: On per settings. NIGHT: On 15 minutes at 12 AM, 6 AM, 12 PM, 6 PM (only if is night).	DAY: On due to temperature or humidity. NIGHT: On due to temperature or humidity.	2 °F, 2 %rH	50 PPM
CODE	1	0	1	2

The code for daytime pumping per settings with moisten cycles at night at fixed times is 1. The code for fan on day or night due to temperature or humidity is 0. This is a recommended default and thus 0. The code for "2 °F, 2 %rH" is 1. The code for "50 PPM" is 2. Therefore the codes would be 1,0,1, and 2. Turn the Select Knob to point to OPTIONS. Turn the Set Knob to show 1012. Turn the Select Knob to RUN and now the new setting will be used.

When turning the Set Knob the digits will only go from 0-3 rather than the usual 0-9 because that is the range of the codes. For example, if the display is 0013 then turning the Set Knob in the INCREASE direction the display will change from 0013 to 0020, not to 0014. Turning the Set Knob in the INCREASE direction the display will roll-over from 3333 to 0000. Turning the Set Knob in the DECREASE direction will do the reverse, it will roll-under from 0000 to 3333.

## PUMP OPTIONS

### PUMP MODE 0

Pump Mode 0 is the default. This is used with a growing medium that does not require moistening at night. During the day (when the lamp is on or, if using a photocell when there is natural lighting), the pump operates based on its PUMP INTERVAL and PUMP DURATION settings. At night, the pump is off.

### PUMP MODE 1

Pump Mode 1 is used to keep roots moist during night time periods of no pumping. During the day the pump operates based on its PUMP INTERVAL and PUMP DURATION settings. At night, the pump comes on for 15 minutes at 12 AM, 6 AM, 12 PM, 6 PM. Example: The lamp is on from 7 AM to 7 PM. Pumping is set for 10 minutes every hour. Then pumping will occur for 10 minutes at 7 AM, 8 AM, 9 AM, 10 AM, 11 AM, 12 PM, 1 PM, 2 PM, 3 PM, 4 PM, 5 PM, and 6 PM. It will not come on at 7 PM because it will be night. At 12 AM (midnight) and 6 AM it will do a moisture cycle and pump for 15 minutes. It will not do a moisture cycle at 12 AM (noon) or 6 PM because the lamp is on and therefore it is not night. The same would occur in a photocell mode where the day and night were determined by natural and (if present) artificial light.

### PUMP MODE 2

Pump Mode 2 is used when the pump should operate day and night based on its PUMP INTERVAL and PUMP DURATION settings. The lamp and photocell are ignored.

### PUMP MODE 3

Pump Mode 3 is used for aeroponics or similar applications. The Pump Interval is 4 minutes and the duration is 1 minute, day or night. Thus the pump is on for 1 minute, off for 3 minutes, on for 1 minute, and so on. The PUMP INTERVAL and PUMP DURATION settings are ignored.

**CAUTION!** Because of the high rate of pump cycling in Pump Mode 3, the Plant Pro should only directly switch a small pump in occasional usage. For regular usage or with larger pumps (such as 1/6 H.P. or larger), a Solatel PWX-1 Power Expander is required. The Plant Pro will trigger the Power Expander to switch on the pump. For larger pumps this may also be needed when the total current drawn by the lamp, pump, fan and CO2 dispenser is more than the Plant Pro can provide by itself.

## VENT FAN OPTIONS

### VENT FAN MODE 0

Vent Fan Mode 0 is the default. Previously, the Plant Pro only operated in this mode. This is used when the fan should turn on when the temperature or humidity is too high based on the FAN MAX TEMPERATURE and FAN MAX HUMIDITY settings, day or night. The fan is not on at any other time.

### VENT FAN MODE 1

Vent Fan Mode 1 is used when the fan should not turn on at night. This may be required if night time outdoor temperature or humidity is a problem and thus air exchange only makes growing area climate worse. The fan will turn on when the temperature or humidity is too high based on the FAN MAX TEMPERATURE and FAN MAX HUMIDITY settings only during the day. At night it will ignore temperature and humidity and remain off.

### VENT FAN MODE 2

Vent Fan Mode 2 is used when regular air exchange at night is desired, even if temperature and humidity are within settings. The fan will turn on when the temperature or humidity is too high based on the FAN MAX TEMPERATURE

and FAN MAX HUMIDITY settings, day or night. It will also turn on for 5 minutes at the beginning of each hour during the night.

### VENT FAN MODE 3

Vent Fan Mode 3 is used when regular air exchange at night is desired, but the fan should otherwise remain off at night. This is a compromise where night time outdoor climate and stagnant air in the grow room are both problems. The fan will turn on when the temperature or humidity is too high based on the FAN MAX TEMPERATURE and FAN MAX HUMIDITY settings only during the day. At night it will turn on for 5 minutes at the beginning of each hour but otherwise ignore temperature and humidity and remain off.

### ADJUSTABLE TEMPERATURE, HUMIDITY AND CO2 OFFSET MODES

Previously, switching occurred when the temperature, humidity or photocell reading is 1 unit above or below the relevant setting. For CO2 it is 10 PPM, which is effectively one unit given that the Plant Pro only resolves to 10 PPM. These offsets for temperature, humidity, and CO2 are now adjustable. Photocell offset remains fixed at 1 unit. The Plant Pro allows adjustment of the switching point's offset from the set point. An alternative way of describing this is the span or dead band between the two switching points. Span or dead band numbers are double the equivalent offset value when describing the same conditions. The offset adjustment for temperature and humidity is combined because they both control the vent fan. CO2 offset for use with a CO2 monitor is separately adjustable.

### DETERMINING OFFSET TO BE USED

The best offset value depends on a variety of factors, such as growing area size and insulation, vent fan capacity and natural air exchange, lamp wattage, number and size of plants, CO2 dispensing rate, location of CO2 dispenser and monitor, and so on. In general, if the device is switching on and off too often, then the offset should be increased. If the measurement varies too much before the device turns on or off, the offset should be decreased. Changes in factors mentioned above may also be needed.

**NOTE:** The switching point must be within the sensor's range. For example, if FAN MAX HUMIDITY is 97 %rH and the offset is 4 %rh, then the humidity would have to get to 101 %rH to turn on - impossible. The Fan would never be turned on due to humidity.

### TEMPERATURE AND HUMIDITY OFFSET MODE 0

Temperature and Humidity Offset Mode 0 is the default. Previously, the Plant Pro only operated in this mode. The fan switches on when either the temperature is 1 °F greater than FAN MAX TEMPERATURE or when the humidity is 1 %rH greater than FAN MAX HUMIDITY. The fan switches off when both the temperature is 1 °F less than FAN MAX TEMPERATURE and the humidity is 1 %rH less than FAN MAX HUMIDITY. Other modes are equivalent using their respective offset values.

### EXAMPLES - TEMPERATURE AND HUMIDITY OFFSET

**NOTE:** For clarity, only one setting, temperature or humidity, is show at a time in the examples. Both settings operate similarly.

Mode 0 - offset = 1 unit:

The FAN MAX TEMPERATURE setting is 85 °F. Fan turns on at 86 °F (85 °F + 1 °F) and off at 84 °F (85 °F - 1 °F).

Mode 1 - offset = 2 units:

The FAN MAX HUMIDITY setting is 80 %rH. Fan turns on at 82 %rH (80 %rH + 2 %rH) and off at 78 %rH (80 %rH - 2 %rH).

Mode 2 - offset = 3 units:

The FAN MAX TEMPERATURE setting is 85 °F. Fan turns on at 88 °F (85 °F + 3 °F) and off at 82 °F (85 °F - 3 °F).

Mode 3 - offset = 4 units:

The FAN MAX HUMIDITY setting is 80 %rH. Fan turns on at 84 %rH (80 %rH + 4 %rH) and off at 76 %rH (80 %rH - 4 %rH).

## CO2 OFFSET MODE 0

CO2 Offset Mode 0 is the default. Previously, the Plant Pro only operated in this mode.

The CO2 outlet switches on when the CO2 level is 10 PPM less than the CO2 setting. The CO2 outlet switches off when the CO2 level is 10 PPM more than the CO2 setting. Other modes are equivalent using their respective offset values.

## EXAMPLES - CO2 OFFSET

Mode 0 - offset = 10 PPM:

The CO2 setting is 1500 PPM. CO2 outlet turns on at 1490 PPM (1500 PPM - 10 PPM) and off at 1510 PPM (1500 PPM + 10 PPM).

Mode 1 - offset = 20 PPM:

The CO2 setting is 1500 PPM. CO2 outlet turns on at 1480 PPM (1500 PPM - 20 PPM) and off at 1520 PPM (1500 PPM + 20 PPM).

Mode 2 - offset = 50 PPM:

The CO2 setting is 1500 PPM. CO2 outlet turns on at 1450 PPM (1500 PPM - 50 PPM) and off at 1550 PPM (1500 PPM + 50 PPM).

Mode 3 - offset = 100 PPM:

The CO2 setting is 1500 PPM. CO2 outlet turns on at 1400 PPM (1500 PPM - 100PPM) and off at 1600 PPM (1500PPM + 100PPM).

## PHOTOCELL MODES

### OVERVIEW

Growers with greenhouses economize by using natural light from the sun. Some growers rely only on natural light. Other growers may wish to add artificial lighting to supplement or extend natural light. This could be due to seasonal changes that result in low light levels and/or short days. Also the grower may wish for longer lighting periods than natural daylight can provide, often times to promote vegetative growth or fruiting. A grower may have a system where artificial lights are already controlled and the Plant Pro is being added not to control the lights but to control other functions dependent on the presence of light. Plant Pro, in addition to the Time Clock Mode discussed previously in the **Lamp** section (page 22), has three Photocell Modes to handle all these situations where supplementation or extension of the natural lighting period is required. There is one supplementation mode and two extension modes.

In Photocell Modes, operation is controlled by the Photocell Sensor, turning on and off depending on light levels you set. The three Photocell Modes of operation maximize natural light utilization or combination natural light and supplemental artificial light. Since many Plant Pro functions are dependent on the presence of light, these Photocell Modes allow for normal operation with natural light. If the Plant Pro provides supplemental artificial light, normal operation also continues, during which time the Photocell Sensor is ignored.

The Photocell Sensor must first be setup for the Photocell Modes to be used. See **Photocell Setup** (page 38).

### SUNRISE AND SUNSET

The Photocell Sensor tells the Plant Pro how much light there is. You tell the Plant Pro the dividing line between when the sun is up (lots of sunlight) or the sun is down (dark). This dividing line is the PHOTOCELL setting. Unlike equipment with a fixed dividing line, the Plant Pro allows you to adjust operation based on your own particular environment. Sunrise is when the Photocell Sensor detects that the sun changed from being *down* to being *up*. In other words, sunrise is when the light level measured by the Photocell Sensor changes from *less* than the PHOTOCELL setting (the value you set) to *more* than the PHOTOCELL setting. Sunset is the reverse. Sunset is when the light level

measured by the Photocell Sensor changes from *more* than the PHOTOCELL setting to *less* than the PHOTOCELL setting.

## LAMP AND SUN INTERACTION

The LAMP START setting tells the Plant Pro when to turn the lamp on. In Photocell Modes the lamp can be set to turn on at sunrise or at sunset. The LAMP DURATION setting tells the Plant Pro how long the lamp will stay on. The lamp can be set to stay on until sunset or the number of hours you want. The settings to control the lamp in the Photocell Modes are LAMP START, LAMP DURATION and PHOTOCELL. Not every combination of these three settings is valid. If an invalid setting combination is made, then when the Select Knob is moved to RUN, the display will start flashing. See **Faults** (page 40) if this happens.

## SUMMARY OF PHOTOCELL MODES

MODE	LAMP TURNS ON	LAMP TURNS OFF
Natural Duration	<i>Sunrise</i>	<i>Sunset</i>
Fixed Duration	<i>Sunrise</i>	When the lamp has been on for LAMP DURATION hours
Total Duration	<i>Sunset</i>	When the sun + the lamp have been on for LAMP DURATION hours <i>total</i>

## NATURAL DURATION MODE

In Natural Duration Mode the lamp, pump, and CO2 are on at sunrise until sunset. This is the natural duration of the day as measured by the photocell. Natural Duration Mode is used primarily in two situations. The first case is where the day is long enough but the sun is not bright enough. In this case a lamp is turned on during the day. The second case is where the natural light is adequate and there is no lamp. This is the mode greenhouse growers who do not utilize artificial lighting will want to use. The lamp outlet on the Plant Pro is thus unused. The pump and CO2 operate only when there is sunlight. At the beginning of the first hour after sunrise, that is, when the minutes are at :00, the pump and CO2 will start their cycles. This keeps all the devices working together. Pump and CO2 will turn off immediately at sunset. Natural Duration Mode is also used in the same fashion if you have a lighting system that is separately controlled but want to use the Plant Pro to control the pump, vent fan, and CO2. LAMP START and LAMP DURATION are not set to specific times but to "PCon" ("**PhotoCell on**"). You don't tell the Plant Pro what time to turn on and for how long, you just tell it to watch the sun with the Photocell Sensor.

For example, say you are have a greenhouse that just uses the sun and has no artificial lighting. So you will use Natural Duration Mode. You set the LAMP START and LAMP DURATION both to PCon. You set PHOTOCELL according to **Photocell Setup** (page 38). The following would happen:

TIME	SUN	PUMP AND CO2
5:42 AM	Down	Off
5:43 AM	Up (sunrise)	Off
5:59 AM	Up	Off
6:00 AM	Up	Start cycling at beginning of first hour after sunrise
7:27 PM	Up	Still cycling
7:28 PM	Down (sunset)	Off - stop cycling at sunset

Natural Duration Mode is also used if the length of the day is adequate but added light intensity is needed. A lamp is then used to supplement the natural daylight. The lamp is on when the sun is up. The lamp, pump, and CO2 don't actually turn on at sunrise, they turn on at the beginning of the first hour after sunrise, that is, when the minutes are at :00. At that time the lamp will turn on and the pump and CO2 will start their cycles. This keeps all the devices working

together. Lamp, pump and CO2 will turn off immediately at sunset. LAMP START and LAMP DURATION are not set to specific times but to "PCon" ("**PhotoCell on**"). You don't tell the Plant Pro what time to turn on and for how long, you just tell it to watch the sun with the Photocell Sensor.

For example, say you wanted the lamp to be on while the sun is up. So you will use Natural Duration Mode. You set the LAMP START and LAMP DURATION both to PCon. You set the value of the PHOTOCCELL setting according to **Photocell Setup** (page 38). The following would happen:

TIME	SUN	LAMP	PUMP AND CO2
5:42 AM	Down	Off	Off
5:43 AM	Up (sunrise)	Off	Off
5:59 AM	Up	Off	Off
6:00 AM	Up	Turns on at beginning of first hour after sunrise	Start cycling at beginning of first hour after sunrise
7:27 PM	Up	Still on	Still cycling
7:28 PM	Down (sunset)	Turns off at sunset	Off - stop cycling at sunset

### FIXED DURATION MODE

In Fixed Duration Mode the lamp, pump, and CO2 are on at sunrise for a fixed duration. Fixed Duration Mode should be used when the sun alone cannot provide sufficient light intensity or duration and is primarily used to supplement the lamp with any "free" light available. The fixed duration makes sure that the number of hours of light does not fall below a minimum. Starting at sunrise rather than a fixed time allows for the maximum use of sunlight without requiring regular adjustment of when the lamp turns on to make up for the changing sunrise time. The lamp, pump, and CO2 don't actually turn on at sunrise, they turn on at the beginning of the first hour after sunrise, that is, when the minutes are at :00. At that time the lamp will turn on and the pump and CO2 will start their cycles. This keeps all the devices working together. LAMP START is not set to a specific time but to "PCon" ("**PhotoCell on**"). You don't tell the Plant Pro what time to turn on, you just tell it to watch the sun with the Photocell Sensor. The lamp will turn off after it has been on for the number of hours set in LAMP DURATION. The lamp ignores sunset. If sunset has already happened, then the pump and CO2 will also turn off because there is now no light from either the lamp or the sun. If the sun is still up when the lamp turns off, the pump and CO2 will remain on until sunset to take advantage of any extra sunlight.

For example, say you want your plants to get at least 12 hours of light from the lamp. Any extra light from the sun is a bonus. So you will use Fixed Duration Mode. You set the LAMP START to PCon. You set LAMP DURATION to 12:00. You set the value of the PHOTOCCELL setting according to **Photocell Setup** (page 38). The following would happen:

TIME	SUN	LAMP	PUMP AND CO2
5:42 AM	Down	Off	Off
5:43 AM	Up (sunrise)	Off	Off
5:59 AM	Up	Off	Off
6:00 AM	Up	Turns on at beginning of the first hour after sunrise	Start cycling at beginning of the first hour after sunrise
6:00 PM	Up	Turns off because it has been on for 12 hours, the setting in LAMP DURATION	Still cycling, doesn't care about lamp turning off because sun is still up
7:27 PM	Up	Off	Still cycling because the sun is still up
7:28 PM	Down (sunset)	Off	Off -stop cycling at sunset because no lamp or sun

In the above example, when the lamp turned off after 12 hours the sun was still up. The pump and CO2 kept cycling to take advantage of the extra light. Instead, say the day was shorter but all your settings were the same.

TIME	SUN	LAMP	PUMP AND CO2
5:42 AM	Down	Off	Off
5:43 AM	Up (sunrise)	Off	Off
5:59 AM	Up	Off	Off
6:00 AM	Up	Turns on at beginning of first hour after sunrise	Start cycling at beginning of first hour after sunrise
4:44 PM	Up	Still on.	Still cycling
4:45 PM	Down (sunset)	Still on, doesn't care about sunset because it hasn't been on for 12 hours yet, the setting in LAMP DURATION	Still cycling, doesn't care about sunset because the lamp is still on
6:00 PM	Down	Turns off because it has been on for 12 hours, the setting in LAMP DURATION	Off - stop cycling when lamp turns off because no lamp or sun.

In the above example the sun went down before the lamp was finished with its 12 hours. The pump and CO2 stayed on for the lamp. When the lamp turned off, so did the pump and CO2.

## TOTAL DURATION MODE

In Total Duration Mode the lamp, pump, and CO2 are on at sunrise for a fixed total duration of sun and lamp. Total Duration Mode should be used when the sun alone provides sufficient light intensity but the day is too short. The lamp must also be able to provide sufficient light intensity by itself. In this case either the sun is up or the lamp is on but not both. This minimizes lighting costs because the lamp turns on at sunset only if the day is too short. It does not require regular adjustment of a time clock to make up for a changing day length. At the beginning of the first hour after sunrise, the Plant Pro starts counting the hours the sun has been up. The sun must be up at least until the beginning of the hour or the Plant Pro ignores it. At the beginning of the hour the pump and CO2 start their cycles. The lamp remains off. At sunset, the Plant Pro compares the number of hours the sun has been up and the number of hours you set in LAMP DURATION. If the LAMP DURATION setting is *equal or smaller* than the number of hours the sun has been up, then the day was long enough. The pump and CO2 turn off at sunset. The lamp never turns on. If the LAMP DURATION setting is *larger* than the number of hours the sun has been up, then the day was too short. The lamp turns on at sunset and the pump and CO2 continue their cycles. The lamp, pump and CO2 will then turn off when the total hours of sun and lamp reaches the LAMP DURATION setting. You have increased the length of the day to your minimum value. LAMP START is not set to a specific time but to "PCLn" ("**PhotoCell Lengthens the day**"). You don't tell the Plant Pro what time to turn on (if at all), you just tell it to watch the sun with the Photocell Sensor. LAMP DURATION is set to the minimum number of hours you want for total sun and lamp.

For example, say you want your plants to get at least 12 hours of light. You don't care whether the light is from the sun or the lamp. Any extra light from the sun is a bonus. So you will use Total Duration Mode. You set the LAMP START to PCLn. You set LAMP DURATION to 12:00. You set the PHOTOCCELL setting according to **Photocell Setup** (page 38). The following would happen:

<b>TIME</b>	<b>SUN</b>	<b>LAMP</b>	<b>PUMP AND CO2</b>
5:42 AM	Down	Off	Off
5:43 AM	Up (sunrise)	Off	Off
5:59 AM	Up	Off	Off
6:00 AM	Up	Still off. Plant Pro starts counting the hours of light beginning at the first hour after sunrise	Start cycling at beginning of first hour after sunrise
6:00 PM	Up	Still off. The sun has now been up for 12 hours of light from the sun, the setting in LAMP DURATION	Still cycling, doesn't care about the 12 hours of light because sun is still up
7:27 PM	Up	Off	Still cycling because the sun is still up
7:28 PM	Down (sunset)	Stays off. Never comes on because there was already 12 hours of light from the sun, the setting in LAMP DURATION	Stop cycling at sunset because no lamp or sun

In the above example, the sun provided enough hours of light and the lamp never needed to come on. Instead, say the day was shorter but all your settings were the same.

<b>TIME</b>	<b>SUN</b>	<b>LAMP</b>	<b>PUMP AND CO2</b>
5:42 AM	Down	Off	Off
5:43 AM	Up (sunrise)	Off	Off
5:59 AM	Up	Off	Off
6:00 AM	Up	Still off. Plant Pro starts counting the hours of light beginning at the first hour after sunrise	Start cycling at beginning of first hour after sunrise
4:44 PM	Up	Off.	Still cycling
4:45 PM	Down (sunset)	Turns on because there hasn't been 12 hours of light yet, the setting in LAMP DURATION	Still cycling, doesn't care about sunset because the lamp is now on
6:00 PM	Down	Turns off because there has been 12 hours of light, the setting in LAMP DURATION. Part was provided by the sun, the rest by the lamp.	Stop cycling when lamp turns off because no lamp or sun.

In the above example the sun went down before there were 12 hours of light. The lamp then came on to make up the difference. The pump and CO2 were cycling for the sun and then for the lamp.

If you want continuous pump and CO2 cycling and continuous light (from either sun or lamp), set LAMP DURATION to 24:00 while using Total Duration Mode.

## THE LAMP START SETTING

The LAMP START setting tells the Plant Pro when to turn on the lamp. In Photocell Modes, LAMP START is never set to an actual time but to either "PCon" or "PCLn". When LAMP START is set to PCon ("PhotoCell **on**"), the lamp starts after sunrise at the beginning of the next hour, that is, when the minutes are at :00. When LAMP START is set to PCLn ("PhotoCell **L**engthens the day"), the lamp starts at sunset, whatever the minutes are. The sun, however, must

have been up at the beginning of the last hour for PCLn to work. When turning the Set Knob in the INCREASE direction, when LAMP START gets to 11:00 AM it next shows 12:00 PM (noon). LAMP START then continues through the day. When LAMP START gets to 11:00 PM it next shows PCon and then PCLn. After PCLn, LAMP START next shows 12:00 AM (midnight). LAMP START then continues through the morning to 11:00 AM and continues as described above. By turning the Set Knob in the DECREASE direction, the reverse will happen. LAMP START must be set to either PCLn or PCon for a valid Photocell Mode.

## THE LAMP DURATION SETTING

The LAMP DURATION setting tells the Plant Pro how long to leave the lamp on once it starts. Photocell Modes allow this to be set based on time or the sun. LAMP DURATION can be an actual time from 0 to 24 hours. Only the hours can be set. When setting LAMP DURATION, AM or PM is not indicated because it doesn't apply. LAMP DURATION can also be "PCon" ("PhotoCell on"). When LAMP DURATION is set to PCon, the lamp stays on until sunset. When the Set Knob is turned in the DECREASE direction, LAMP DURATION eventually shows 00:00. Even though the knob can still be turned in that direction, the number won't get any smaller. When LAMP DURATION is set to 00:00, the lamp will always be off. When the Set Knob is turned in the INCREASE direction, LAMP DURATION eventually shows 24:00. When LAMP DURATION is set to 24:00, the lamp will always be on. Turning further, LAMP DURATION next shows PCon and then will change no more. LAMP DURATION can be set to any of these values in Photocell Modes, though some combinations with LAMP START are not valid.

## THE PHOTOCELL SETTING

For the Photocell Modes, the grower is interested in detecting low light levels as seen at sunrise and sunset. The PHOTOCELL setting tells the Plant Pro the level of light needed to determine sunrise and sunset. Sunrise is when the light level measured by the Photocell Sensor changes from *less* than the PHOTOCELL setting to *more* than the PHOTOCELL setting. Sunset is the reverse, when the light level measured by the Photocell Sensor changes from *more* than the PHOTOCELL setting to *less* than the PHOTOCELL setting. The value of PHOTOCELL can be set from 0 to 100. Zero is complete darkness and 100 is very bright light. This is just a convenient range to set the light level and does not match with foot-candles or lux. When viewing the PHOTOCELL setting, the PHOTO indicator will light. When the Set Knob is turned in the DECREASE direction, it eventually shows 0. Even though the knob can still be turned in that direction, the number won't get any smaller. PHOTOCELL should not be set to 0 since it will not be possible to determine sunrise and sunset because the actual Photocell Sensor value can never get below this. When the Set Knob is turned in the INCREASE direction, PHOTOCELL eventually shows 100. PHOTOCELL can not be set to a higher light level than 100. PHOTOCELL should not be set to 100 since it will not be possible to determine sunrise and sunset because the actual Photocell Sensor value can never get above 100. Turning further, PHOTOCELL next shows "nonE" and then will change no more. A PHOTOCELL setting of "nonE" is a special case value which tells the Plant Pro that there is no Photocell Sensor and therefore the Photocell Sensor should be ignored. PHOTOCELL is set to "nonE" only in Time Clock Mode. Do not set PHOTOCELL to "nonE" in Photocell Modes or there will be a Setting Fault when the Select Knob is turned to RUN. The display will start flashing. See **Faults** (page 40) if this happens.

## PHOTOCELL SETUP

This must be done to use any of the Photocell Modes. The PHOTOCELL setting should be approximately the actual Photocell Sensor value during sunrise or sunset. This test should be done with the Photocell Sensor mounted in the same location as it will be used during normal operation. The Photocell Sensor must be oriented to see natural light rather than the lamp. Be careful that it is oriented away from any night time light sources such as street lights, porch lights, auto headlights, window lights, and such. Do this test as the sun is coming up or going down where there is an intermediate light level between day and night. This determines the sunrise/sunset level of the Photocell Sensor which is then used as the PHOTOCELL setting. In experiments done by Solatel, a PHOTOCELL setting of approximately 20 was about right. However, each grower may have a different idea about what light level should be used for sunrise and sunset. The best way to determine this light/dark threshold is to monitor the light yourself using the steps in this section. Use a lower value for PHOTOCELL to determine sunrise and sunset when darker. Use a higher value for PHOTOCELL to determine sunrise and sunset when brighter.

Mount the Photocell Sensor as described in the **Photocell Sensor** (page 15) installation section. Do the following steps when the sun is just coming up or going down.

STEP	SELECT KNOB	SET KNOB
1	RUN	DO THIS TEST AT SUNRISE OR SUNSET USING SETUP AS DESCRIBED ABOVE. Turn 6 or more "clicks" in the INCREASE direction. The display may blank. Turn 1 click in the DECREASE direction. The PHOTO indicator will stay on. This will get the display to continuously show the actual Photocell Sensor value. Write down the number shown.
2	PHOTOCELL	Turn to show the number written down in step 1. Do not set to "nonE".
3	RUN	Now the new setting will be used. If the display starts to flash, see <b>Faults</b> (page 40).

### SETTING NATURAL DURATION MODE

STEP	SELECT KNOB	SET KNOB
1	LAMP START	Turn to show "PCon". If the PM indicator is on, turn in the INCREASE direction. Otherwise, turn in the DECREASE direction.
2	LAMP DURATION	Turn in the INCREASE direction until "PCon" shows.
3	PHOTOCELL	This must have been set as described in <b>Photocell Setup</b> (page 38). Do not set to "nonE".
4	RUN	Now the new settings will be used. If the display starts to flash, see <b>Faults</b> (page 40).

### SETTING FIXED DURATION MODE

STEP	SELECT KNOB	SET KNOB
1	LAMP START	Turn to show "PCon". If the PM indicator is on, turn in the INCREASE direction. Otherwise, turn in the DECREASE direction.
2	LAMP DURATION	Turn to show the number of hours for the lamp to remain on. Do not set to 24:00 because the lamp will be on continuously. Do not set to "PCon".
3	PHOTOCELL	This must have been set as described in <b>Photocell Setup</b> (page 38). Do not set to "nonE".
4	RUN	Now the new settings will be used. If the display starts to flash, see <b>Faults</b> (page 40).

## SETTING TOTAL DURATION MODE

STEP	SELECT KNOB	SET KNOB
1	LAMP START	Turn to show "PCLn". If the AM indicator is on, turn in the DECREASE direction. Otherwise, turn in the INCREASE direction.
2	LAMP DURATION	Turn to show the total minimum number of hours for the sun and lamp to be on. If you want continuous light from either the sun or lamp set to 24:00. Do not set to 'PCon'.
3	PHOTOCELL	This must have been set as described in <b>Photocell Setup</b> (page 38). Do not set to "nonE".
4	RUN	Now the new settings will be used. If the display starts to flash, see <b>Faults</b> (page 40).

## FAULTS

### OVERVIEW

When the display is flashing it is because a fault has occurred. Even if the source of the fault is removed, the fault must be cleared as described below to go back to normal. In addition to the flashing, there may be additional results depending on the fault. There are four types of faults. A **Clock Fault** happens when the clock has not been set since the power came on and causes flashing. A **Setting Fault** results from an invalid setting and in addition to the flashing will shut off all outlets but the vent fan when in default Pump and Fan Option Modes (may be different in other modes). A **Flood Fault** or **Panic Fault** will cause flashing and shut off all outlets.

### FAULT DETERMINATION

STEP	SELECT KNOB	SET KNOB
1	CLEAR FAULTS	View display. It will show "CSFP" or similar. Faults that are not active will show a "-". Set Knob has no effect.

### **C = CLOCK FAULT (CLOCK NOT SET SINCE POWER ON)**

A Clock Fault always occurs when the system is turned on. Clock Fault does not prevent the system from operating but does remind the user that the time needs to be set. The initial time will have the same hours as before power went off and the minutes will start at :00. The clock will run with this incorrect time and outlets will be switched on or off accordingly. Hours and/or minutes must be changed for the Clock Fault to be cleared.

STEP	SELECT KNOB	SET KNOB
1	CLEAR FAULTS	View display. It will show "C---" with additional letters if other faults are also active. Set Knob has no effect.
2	SET HOURS	Turn to show the correct hours. If the correct hours show but not the correct AM or PM, keep turning until all are correct
3	SET MINUTES	Turn to show the correct minutes.
4	RUN	Now the new settings will be used. If there are no other faults, the display should stop flashing. If it is still flashing, determine faults again as above

## S = SETTING FAULT (INVALID SETTING IN PHOTOCELL CONTROLLED LAMP MODE)

There are four valid lamp control / Photocell Sensor setting combinations. If an invalid combination is set, then the Plant Pro is unable to determine the proper action. The Plant Pro will then have a Setting Fault. The Plant Pro will keep the lamp off. This will result in the pump and CO2 also being off. Thus only the vent fan will operate. This is when in default Pump and Fan Option Modes (may be different in other modes). See **Options** (page 29) for more information. To alert the user of the Setting Fault, the display flashes. Flashing will start when the Select Knob is moved to RUN and the Plant Pro tries to use the invalid settings. The following table shows the only valid setting combinations.

CASE	TYPE	LAMP START	LAMP DURATION	PHOTOCELL
1	Time Clock Mode	time	time	nonE preferred, value OK
2	Natural Duration Mode	PCon	PCon	value - nonE is invalid
3	Fixed Duration Mode	PCon	time	value - nonE is invalid
4	Total Duration Mode	PCLn	time	value - nonE is invalid

One of the above valid setting combinations must be used to stop the flashing. Correct the settings as follows.

STEP	SELECT KNOB	SET KNOB
1	CLEAR FAULTS	View display. It will show "-S--" with additional letters if other faults are also active. Set Knob has no effect.
2	LAMP START	Turn to show valid setting from table.
3	LAMP DURATION	Turn to show valid setting from table.
4	PHOTOCELL	Turn to show valid setting from table.
5	RUN	Now the new settings will be used. If a valid setting combination has been made and there are no other faults, the display should stop flashing. If it is still flashing, determine faults again as above

## F = FLOOD FAULT

When an electrically conductive material, such as water or nutrient solution, is on the Flood Sensor and completes the circuit, a Flood Fault occurs. This must continue for 1 - 2 seconds for the Flood Fault to happen. Once the Flood Fault occurs, all outlets are shut off and the display begins flashing. Although the clock continues operating, no outlets will turn on. This action continues until the user cleans the Flood Sensor and clears the Flood Fault. Even if the sensor dries off, flashing and all outlets being off will continue until the user follows the steps below to clear the Flood Fault. During the Flood Fault, the Panic circuit on the REMOTE connector becomes an output to signal remote devices so they can take action if needed. Nonconductive liquids, such as distilled or deionized water, oil, and gasoline, may not cause a Flood Fault.

STEP	SELECT KNOB	SET KNOB
1	CLEAR FAULTS	View display. It will show "--F-" with additional letters if other faults are also active. Set Knob has no effect. Clean and dry Flood Sensor. After the sensor has been clean for 1-2 seconds, "F" changes to a "-".
2	RUN	Now the new fault status will be used. If there are no other faults, the display should stop flashing and the outlets operate normally. If it is still flashing, determine faults again as above

## P = PANIC FAULT

The Panic Switch circuit is used to allow a remote device to shut off all outlets. This can be from a switch pressed by the user, a security system, a radio operated remote control, or other device that can complete a circuit. The Panic Switch circuit must be closed for 1 - 2 seconds for the Panic Fault to happen. Once the Panic Fault occurs, all outlets are shut off and the display begins flashing. Although the clock continues operating, no outlets will turn on. This continues until the user opens the circuit and clears the Panic Fault. Even if the Panic Switch circuit opens, flashing and all outlets off will continue until the user follows the steps below to clear the Panic Fault. The specific actions needed to open or close the Panic Switch circuit will depend on the remote device. During the Panic Fault, the Panic Switch circuit becomes an output from the Plant Pro to signal other remote devices so they can take action if needed.

<b>STEP</b>	<b>SELECT KNOB</b>	<b>SET KNOB</b>
1	CLEAR FAULTS	View display. It will show "---P" with additional letters if other faults are also active. Set Knob has no effect. Open the Panic Switch circuit. After the circuit has been open for 1 - 2 seconds, "P" changes to "-".
2	RUN	Now the new fault status will be used. If there are no other faults, the display should stop flashing and the outlets operate normally. If it is still flashing, determine faults again as above

## APPENDIX

### PROBLEM SOLVING

PROBLEM	SUGGESTIONS
The display flashes.	A fault has occurred. The most common is that the clock needs to be set after power on. Set it and put the Select Knob in the RUN position. For more on setting the clock, see <b>Setting The Clock</b> (page 19). For more information, or if that doesn't do it, see <b>Faults</b> (page 40).
A setting was changed but has no effect.	Be sure to put the Select Knob in the RUN position after changing a setting. Only then does the Plant Pro use it. See <b>Run</b> (page 20).
Some settings show strange looking things that aren't regular numbers.	There are "special case" settings which are used for various purposes instead of numbers. These include "nonE", "PCon", and others. See the <b>Operation</b> chapter (page 17) and look in the section on the specific setting. Also see <b>Special Case Values</b> (page 18).
The display is showing numbers but what are they for?	First, check the setting pointed to by the Select Switch. The setting name will usually tell you. See the section in the <b>Operation</b> chapter (page 17) on that setting for more detail. If the setting is RUN, then they are the time or a sensor. See <b>Run</b> (page 20).
Some times when I turn the Set Knob, the display keeps changing forever (like setting the time) but for some settings it gets to a point where it won't change anymore.	Some settings, like the time, will go through their range and start again because it is more convenient given the way they are used. Some settings stop at the end of their range to make it easier to set the minimum or maximum. See the section in the <b>Operation</b> chapter (page 17) on that specific setting or <b>Roll-Over/Under</b> (page 19).
The Temperature (or Humidity or CO2 or Photocell) Sensor was connected but it doesn't do anything.	Check the sensor setting. It must be some value other than "nonE" to work. The setting must be in a range that the sensor reading can get above and below the setting as conditions change. For the Temperature, Humidity, and CO2 Sensors see <b>Fan and CO2</b> (page 24). For the Photocell Sensor, see <b>Photocell Modes</b> (page 29).
The Select Knob is in the RUN position but I want something else displayed or it shows what I want but then changes to something else.	With the Select Knob in the RUN position, turn the Set Knob to get what you want displayed. If the display is sometimes blanked, you probably have it in the Blanking At Night Mode. See <b>Run</b> (page 20). Also if it is alternating between displays but never shows the Photocell Sensor, then it is probably not enabled. To be enabled the sensor related setting must be something other than "nonE". Keep in mind, though, that once a sensor is enabled it is used by the Plant Pro to control things. However, even a sensor that is not enabled can be displayed in a fixed display mode by turning the Set Knob. If a sensor is not connected, it will show a 0.
In a Photocell Mode, the lamp turns on and then strange things happen.	The Photocell Sensor may be seeing the lamp and reacting to its light. The Photocell Sensor should be placed so that it sees the sun but not the lamp. See <b>Photocell Sensor</b> (page 15) installation.
In a Photocell Mode, the sun comes up but activity doesn't start immediately.	Activity starts at the beginning of the first hour after the sunrise. This keeps everything working together. See <b>Photocell Modes</b> (page 29).
The Flood Sensor won't control the Flood and Drain cycle. It just shuts off all the outlets.	The Flood Sensor is not for controlling a Flood and Drain cycle. It is for detecting an overflow onto the floor due to some problem. Put the Flood Sensor where it won't get wet under normal conditions. See <b>Flood Sensor</b> (page 11) installation.

PROBLEM	SUGGESTIONS
After a flood, the Flood Sensor was dried off but the Plant Pro still flashes.	You must do specific steps to clear the flood fault. See <b>Faults</b> (page 40) in general and <b>F = Flood Fault</b> (page 41) for specifics.
Things don't work the way they should.	Check the Options setting. For most users, this should be set to 00 00. See <b>Options</b> (page 29).
The Plant Pro is plugged in but nothing lights up.	You may have it in the Blanking At Night Mode. See <b>Run</b> (page 20). Check the outlet that the Plant Pro is plugged into by plugging in something else and see if that works. Check the circuit breaker on the front of the Plant Pro and see if is tripped (sticking out).
The Plant Pro circuit breaker trips.	The devices plugged into the Plant Pro outlets are drawing too much current. Either use devices that draw less current or contact your retailer about a Solatel PWX-1 or PWX-D20 Power Expander accessory. See <b>Power</b> (page 10).
The building circuit breaker (not the one on the Plant Pro) trips.	There are loads in addition to the Plant Pro on the same building breaker that add up to more than the building breaker can handle. When it trips, see what else gets shut off and move those cords to outlets on other breakers that didn't trip.

## SPECIFICATIONS

- Power supply North American model 120VAC, 60Hz, 15Amps  
International model 230VAC, 50Hz
- Internal current consumption Less than 0.5 Amp
- Outlets Four outlets: Lamp, Pump, Fan, and CO2  
12 Amps each outlet, 14.5 Amps total
- Outlet relay minimum life 1,000,000 operations mechanical  
100,000 operations electrical at 3324VA switching
- Display LED, four digits, 0.5" height, 7 segment  
Indicators for colon, AM, PM, °F, rH, PPM, and Photo
- Temperature Sensor 32-110 °F, usable with reduced accuracy to 5 °F  
sensor accuracy +/- 1 °F at 77 °F (typical)  
sensor response time 100% of reading in 4 minutes  
resolution of 1 °F
- Humidity Sensor 0-100% rH  
sensor accuracy +/- 2%  
15 second time constant  
resolution of 1% rH
- CO2 Sensor 0-2000 PPM  
sensor accuracy +/- 50 PPM typical  
resolution of 10 PPM
- Photocell Sensor 0-100, arbitrary scale  
resolution of 1 unit
- Flood Sensor conductivity type, threshold at approximately 1µSiemens  
continuous conductivity for 1-2 seconds required for response  
safe low voltage/low current, maximum of 5 volts DC, .000003 Amps
- Analog/digital processing seconds A/D conversion +/- 1%, +/- 1 digit, digital filtering time constant 2.1  
seconds  
response time with 0-100% input change for 0-100% output change 13 seconds
- Time keeping 12 hour with AM/PM mode or 24 hour mode (factory set)  
accuracy is based on power line frequency stability @ 50 or 60 Hz (factory set)
- Year 2000 Compliance device is fully Y2K compliant because date is not stored in any format
- Remote connector reserved for future peripherals including Panic circuit
- Case dimensions 9.875" x 7.875" x 2.5" (not including knobs or power cord)

# INDEX

---

## A

APPENDIX .....	41
----------------	----

---

## C

CIRCUIT BREAKER	
LOCATION .....	3
RATING .....	8
CLOCK .....	16
12 HOUR AM/PM MODE .....	17
24 HOUR MODE .....	17
CLOCK FAULT .....	38
COLON .....	17
OVERVIEW .....	16
QUICK START - SETTING THE CLOCK .....	5
ROLL-OVER/UNDER .....	17
SETTING THE CLOCK .....	17
CO2	
ADJUSTABLE OFFSET .....	30
CO2 DURATION SETTING .....	25
CO2 INTERVAL SETTING .....	25
CO2 PPM SETTING .....	25
CO2 SENSOR MODE .....	23
CO2 TIMED MODE .....	22
FAN AND CO2 .....	22
FAN CO2 DELAY SETTING .....	25
OUTLET .....	3
OVERVIEW .....	22
PLANT PRO CONNECTOR .....	3
SENSOR INSTALLATION .....	12
SETTING CO2 SENSOR MODE .....	27
SETTING CO2 TIMED MODE WHEN CO2 DISPENSING EQUIPMENT IS PRESENT .....	26
SETTING THE VENT FAN WHEN NO CO2 DISPENSING EQUIPMENT IS PRESENT .....	26
TANK/GENERATOR INSTALLATION .....	14
COLON .....	17
CONTROLS .....	3

---

## F

FAN	
FAN AND CO .....	22
FAN CO2 DELAY SETTING .....	25
FAN MAX HUMIDITY SETTING .....	24
FAN MAX TEMPERATURE SETTING .....	24
INSTALLATION .....	14
OPTIONS .....	29
OUTLET .....	3
OVERVIEW .....	22
QUICK START - SETTING THE VENT FAN TEMPERATURE .....	6

SETTING THE VENT FAN WHEN NO CO2 DISPENSING EQUIPMENT IS PRESENT .....	26
FAULTS .....	38
CLOCK FAULT .....	38
FAULT DETERMINATION .....	38
FLOOD FAULT .....	39
OVERVIEW .....	38
PANIC FAULT .....	40
SETTING FAULT .....	39
FEATURES .....	2
FLOOD	
FLOOD FAULT .....	39
PLANT PRO CONNECTOR .....	3
SENSOR INSTALLATION .....	9

---

## H

HUMIDITY	
ADJUSTABLE OFFSET .....	30
FAN AND CO2 .....	22
FAN MAX HUMIDITY SETTING .....	24
OVERVIEW .....	22
PLANT PRO CONNECTOR .....	3
SENSOR INSTALLATION .....	11

---

## I

INDICATORS .....	16
LOCATION .....	3
INSTALLATION .....	8
CO2 SENSOR .....	12
FLOOD SENSOR .....	9
HUMIDITY SENSOR .....	11
INTRODUCTION .....	8
LAMP, PUMP, FAN AND CO2 .....	14
PHOTOCELL SENSOR .....	13
PLANT PRO .....	8
POWER .....	8
SENSOR CABLE .....	8
TEMPERATURE SENSOR .....	10

---

## L

LAMP .....	20
INSTALLATION .....	14
LAMP AND SUN INTERACTION .....	32
LAMP DURATION SETTING .....	20
LAMP START SETTING .....	20
OUTLET .....	3
OVERVIEW .....	20
QUICK START - SETTING THE LAMP TIME .....	6
SETTING THE LAMP .....	21

---

## O

OPERATION .....	15
OPTIONS .....	27
ADJUSTABLE SENSOR OFFSET .....	30
FAN.....	29
INTRODUCTION.....	27
PUMP.....	29
OUTLETS .....	14

---

## P

PANIC FAULT .....	40
PHOTOCELL	
FIXED DURATION MODE.....	33
LAMP AND SUN INTERACTION.....	32
LAMP DURATION SETTING .....	36
LAMP START SETTING.....	35
NATURAL DURATION MODE .....	32
OVERVIEW .....	31
PHOTOCELL MODES.....	31
PHOTOCELL SETTING .....	36
PHOTOCELL SETUP .....	36
PLANT PRO CONNECTOR.....	3
SENSOR INSTALLATION.....	13
SETTING FAULT .....	39
SETTING FIXED DURATION MODE .....	37
SETTING NATURAL DURATION MODE.....	37
SETTING TOTAL DURATION MODE.....	38
SUMMARY OF PHOTOCELL MODES .....	32
SUNRISE AND SUNSET.....	31
TOTAL DURATION MODE .....	34
PLANT PRO	
INSTALLATION.....	8
LOCATION OF CONTROLS .....	3
POWER .....	8
POWER ON .....	16
PROBLEM SOLVING.....	41
PUMP .....	21
INSTALLATION.....	14
OPTIONS.....	29
OUTLET .....	3
PUMP DURATION SETTING.....	21
PUMP INTERVAL SETTING.....	21
QUICK START - SETTING THE PUMP TIME.....	6

---

## Q

QUICK START .....	4
CONNECTING THE CABLES .....	5
FINAL CONNECTION AND RUN .....	7
INTRODUCTION.....	4
ITEMS.....	5
OTHER SETTINGS.....	6

SETTING THE CLOCK .....	5
SETTING THE LAMP TIME .....	6
SETTING THE PUMP TIME .....	6
SETTING THE VENT FAN TEMPERATURE.....	6

---

## R

ROLL-OVER/UNDER .....	17
RUN.....	18
DISPLAY BLANKING AT NIGHT .....	19
DISPLAY MODES.....	18
FIXED DISPLAY MODES.....	19
OVERVIEW .....	18
ROTATE (ALTERNATE) THE DISPLAY MODE.....	18
SETTING THE RUN DISPLAY .....	20
SETTINGS VERSUS ACTUAL VALUES.....	18

---

## S

SELECT KNOB.....	15
LOCATION.....	3
SENSOR CABLE .....	8
SET KNOB .....	15
LOCATION.....	3
SETTING	
USING A NEW .....	15
VIEWING AND CHANGING .....	15
SETTINGS VERSUS ACTUAL VALUES .....	18
SPECIAL CASE VALUES.....	16
SPECIFICATIONS .....	42
SUN	
LAMP AND SUN INTERACTION .....	32
PHOTOCELL MODES .....	31
SUNRISE.....	31
SUNSET .....	31

---

## T

TABLE OF CONTENTS .....	1
TEMPERATURE	
ADJUSTABLE OFFSET .....	30
FAN AND CO2 .....	22
FAN MAX TEMPERATURE SETTING.....	24
OVERVIEW .....	22
PLANT PRO CONNECTOR .....	3
SENSOR INSTALLATION .....	10
TIME.....	<i>See</i> CLOCK

---

## V

VENT FAN .....	<i>See</i> FAN
----------------	----------------